



# AUTOBAHN™

## Trochanteric Nailing System **PRO Instrument Set**

*Life moves us* 

The Surgical Technique shown is for illustrative purposes only. The technique(s) actually employed in each case always depends on the medical judgment of the surgeon exercised before and during surgery as to the best mode of treatment for each patient. Additionally, as instruments may occasionally be updated, the instruments depicted in this Surgical Technique may not be exactly the same as the instruments currently available. Please consult with your sales representative or contact Globus directly for more information.

# SURGICAL TECHNIQUE GUIDE

## AUTOBAHN™ Trochanteric Nailing System

Overview .....	4	<b>Long Nail Distal Targeting</b> .....	37
Implant Overview .....	6	Distal Targeting Assembly ...	38
<b>Surgical Technique</b>		Distal Targeting Preoperative Alignment Verification .....	40
1. Patient Positioning .....	8	Distal Targeting C-Arm Positioning .....	41
2. Fracture Reduction .....	8	Distal Targeting C-Arm Adjustment .....	42
3. Determining Femoral Neck Angle .....	9	Distal Targeting Deflection Adjustment .....	43
4. Identifying Entry Point .....	10	Distal Targeting Distal Locking .....	44
5. Inserting Guidewire .....	11	Long Nail Final Construct ....	45
6. Opening the Medullary Canal .....	12	15. Insertion Handle Removal .....	46
7. Determining Nail Length .....	15	Optional: End Cap Insertion .....	47
Optional: Intramedullary Reaming .....	16	Optional: Nail Removal .....	47
8. Nail Insertion .....	18	Instrument Overview .....	48
9. Verifying Nail Anteversion .....	20	AUTOBAHN™ Trochanteric Nail Implants .....	58
10. Guidewire Insertion for Lag Screw .....	22	AUTOBAHN™ EVO Universal Nailing Instrument Set .....	59
Optional: Anti-Rotation Wire Insertion .....	23	AUTOBAHN™ Trochanteric Nailing System PRO Instrument Set .....	60
11. Lag Screw Preparation .....	24	AUTOBAHN™ EVO Universal Screw Set ...	61
12. Inserting the Lag Screw .....	27	AUTOBAHN™ Distal Targeting Instrument Set .....	63
13. Engaging the Set Screw .....	28	AUTOBAHN™ Hip Fastener Implant Set .....	64
14. Distal Locking Screw Insertion ...	29	Important Information .....	65
<b>Short and Intermediate</b>			
Nail Locking .....	29		
Drilling .....	30		
Inserting Locking Screws ....	32		
Short Nail Final Construct. ...	33		
<b>Long Nail Freehand Locking</b> .....	34		
Drilling and Measurement. ...	35		
Inserting Distal Screw .....	36		

# AUTOBAHN™

## Trochanteric Nailing System

The AUTOBAHN™ Trochanteric Nailing System is designed to treat a variety of pertrochanteric femur fractures. The PRO Instrument Set and Distal Targeting System allow for an efficient and streamlined surgical workflow.

### Minimally Invasive Aiming Guides

- Metal tipped Insertion Handle designed to help minimize incision size
- One Insertion Handle connects to multiple aiming arms

### Comprehensive Implant Set

- Accommodates varying patient anatomy with short, intermediate, and long nails
- Offers a variety of neck angles for ideal screw placement

### Preassembled Set Screw

- Designed to streamline procedural workflow
- No additional procedural steps for set screw insertion



## Efficient Instrumentation

### Minimally Invasive Profile

- Metal insertion handle tip features a narrow profile that allows for a minimal incision size without compromising lateral visibility

### Simple Anteversion Check

- Allows for minimally invasive visualization of wire trajectory in the femoral head
- Radiographic markers to show nail anteversion alignment

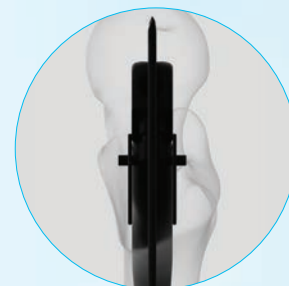

### Targeted Anti-Rotation Wires

- Built-in targeting of wires for femoral head stabilization
- Trajectories converge around the nail, designed to facilitate accurate targeting

### Self-Retaining Sleeves

- Easy, intuitive sleeve retention
- Unlock, insert, and lock positions
- Lock position helps prevent driver sleeve advancement during compression

### Confident Implant Placement

- Lag screw is designed to lock every 90°
- Wire sleeve to measure lag screw length



# IMPLANT OVERVIEW



## Implant Options

- Short, intermediate, and long nails
  - 125° and 130° neck angles
- 10.5mm Lag Screw and Hip Fastener
- 5mm Locking Screw

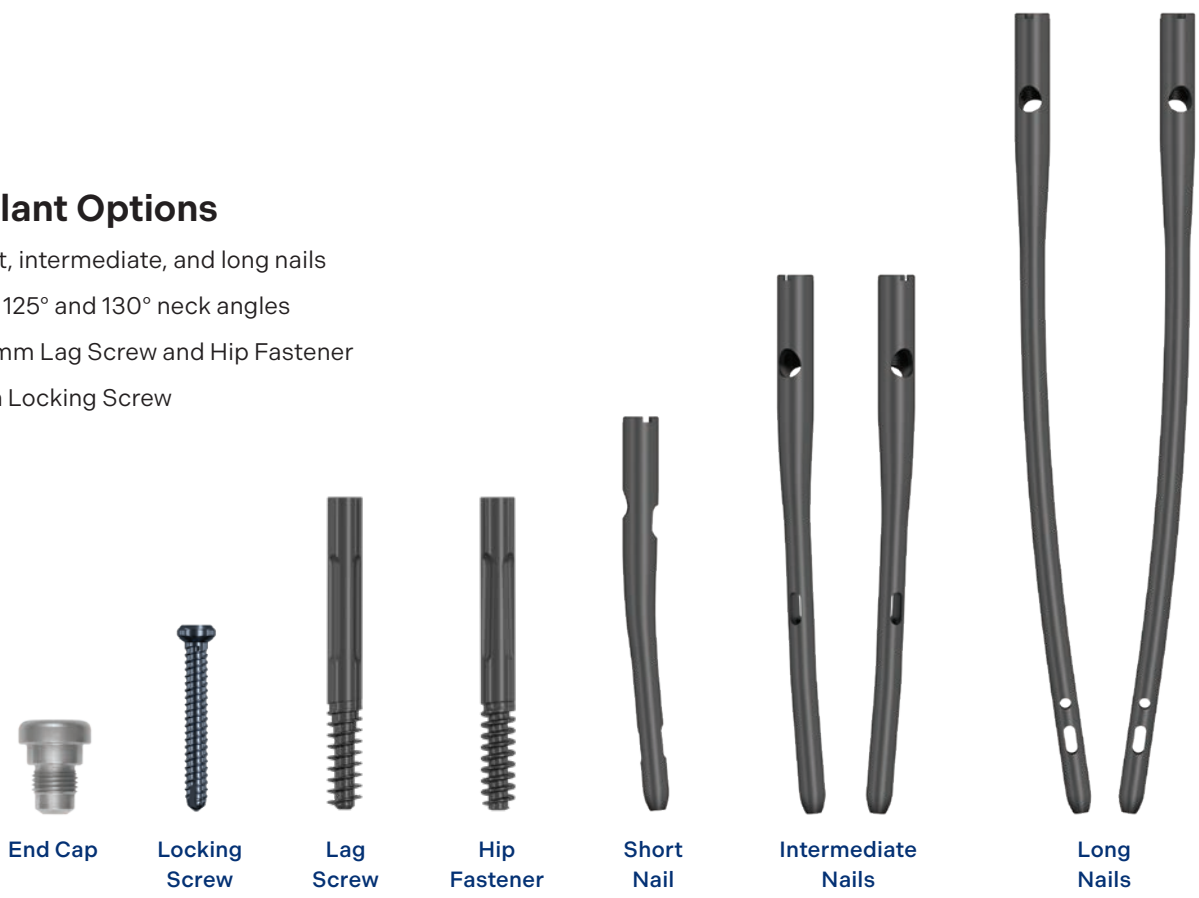

# Streamlined Instruments

## Compressor

- Provides tactile feedback during intraoperative compression



## Reaming Module

- Reamer module included in the universal set
- All reamers are front and side cutting to allow for versatility in reaming
- Flute spacing is designed to help reduce intramedullary pressure during reaming



## Distal Targeting

- Dedicated Distal Targeting System for easy distal locking



## SURGICAL TECHNIQUE

# AUTOBAHN™

## Trochanteric Nailing System

Refer to the device insert (also printed at the back of this technique guide) for important information on the intended use/indications, device description, contraindications, precautions, warnings, and potential risks associated with this system.

### STEP 1 Patient Positioning

Place the patient in a supine or lateral decubitus position. With the injured leg extended, use fluoroscopy to confirm patient positioning.

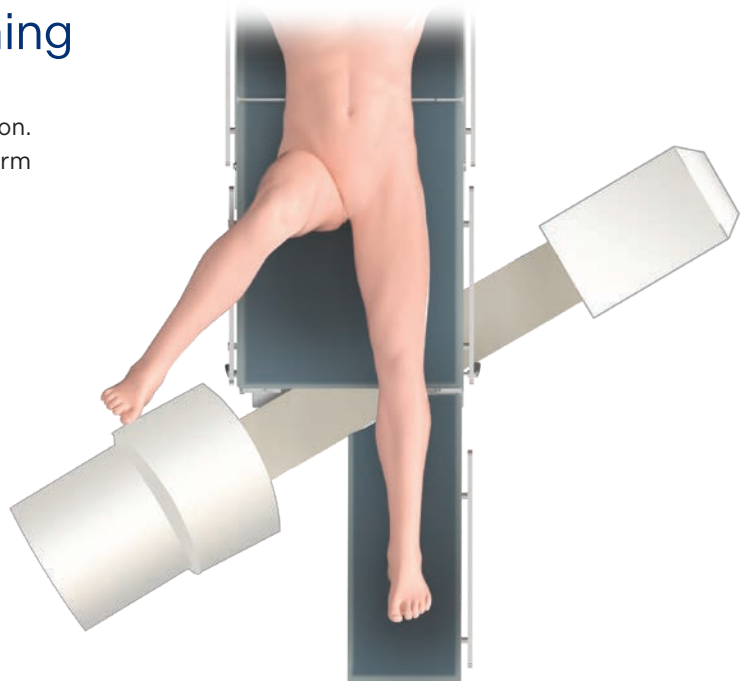

### STEP 2 Fracture Reduction

To reduce the fracture, use traction (indirect measure) or clamp application (direct measure). Anatomic reduction should be performed prior to opening, reaming, and nail insertion. Confirm reduction using fluoroscopy.

**STEP****3**

## Determining Femoral Neck Angle

Use fluoroscopy to measure the neck angle and select the appropriate nail. If desired, use the intact femur from the contralateral side to determine neck angle.

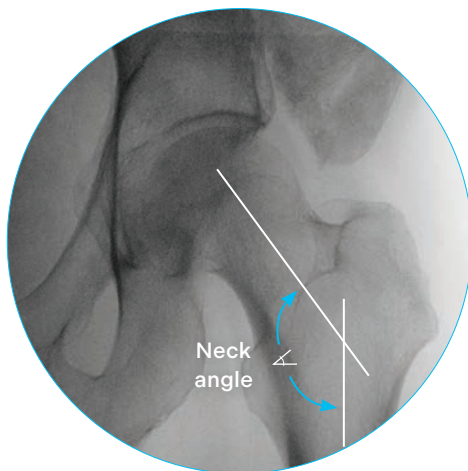

Selecting neck angle

### Determining Nail Diameter

Under fluoroscopy, use the **Nail Length Gauge** to measure the diameter of the intramedullary canal at the isthmus of the femur. The proximal diameter of all AUTOBAHN™ trochanteric nails is 15.5mm. Use this measurement to select the appropriate nail shaft diameter. This step may be performed preoperatively.

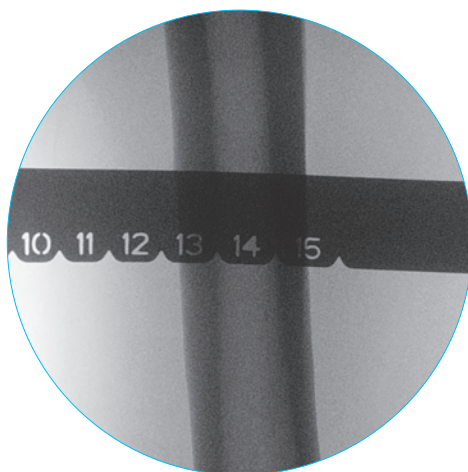

AP view

## STEP 4 Identifying Entry Point

In the AP view, the entry point is the medial tip of the greater trochanter, or 5° lateral of the femoral shaft axis. In the lateral view, the entry point is the center of the greater trochanter in line with the medullary canal.

Confirm entry point and trajectory using fluoroscopy.

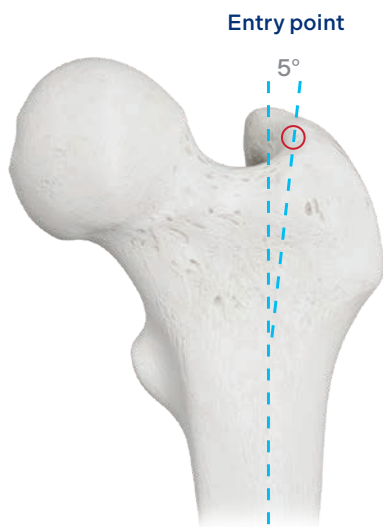

AP view



Lateral view



Axial view (top)

## STEP 5 Inserting Guidewire

Create an incision proximal to the greater trochanter. Separate the muscle fibers.

Attach the **16mm Protection Sleeve** to the **Hall Quick-Connect Handle** and insert the **Multi-Hole Wire Guide, 16mm** into the protection sleeve.

Insert the protection sleeve assembly into the incision until it reaches bone at the desired entry point. Insert a **3.2mm Guidewire, Threaded Drill Point, 285mm** or **3.2mm Guidewire, Drill Point, 285mm** into the center hole of the wire guide until bone is reached. Confirm entry point and trajectory using fluoroscopy. Advance the guidewire to the desired depth.

*Note: A 3.2x400mm guidewire can also be used for entry guidewire.*

Confirm position on fluoroscopy in both AP and lateral views. Remove the wire guide.



If desired, an offset guidewire may be inserted through the multi-hole wire guide to achieve a better starting position. Use the appropriate offset on the wire guide.

The wire guide can be rotated to the desired position before inserting the offset guidewire into bone.

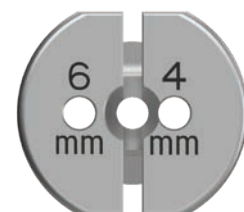

Multi-hole wire guide

**STEP****6**

## Opening the Medullary Canal

Open the medullary canal using the **16mm Conical Opening Drill Bit** placed over the guidewire and through the protection sleeve. Using fluoroscopy, ream approximately 10cm or to the lesser trochanter.

Ensure the reaming path remains in line with the femoral intramedullary canal until reaming is complete. Verify depth under fluoroscopy. Remove the drill bit and guidewire while holding the protection sleeve in place to maintain exposure.

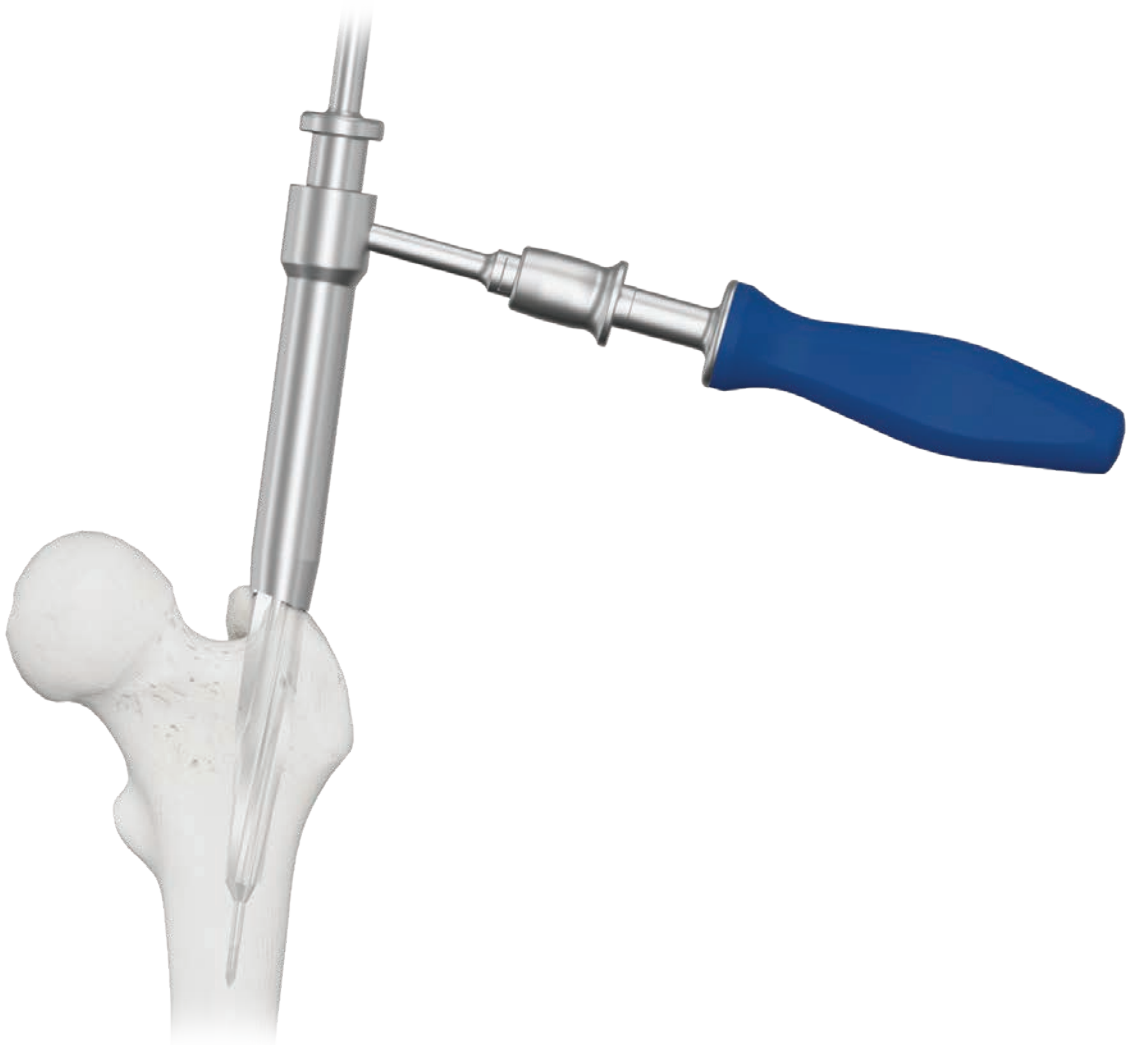

Opening canal with conical drill

# Opening the Medullary Canal (Cont'd)

Alternatively, the **16mm Coring Opening Drill Bit** may be used to open the medullary canal.

Ensure that the centering piece is pushed forward and snapped into the forward position. Open the medullary canal using the 16mm Coring Opening Drill Bit placed over the guidewire and through the protection sleeve. Using fluoroscopy, ream approximately 10cm or to the lesser trochanter.

Ensure the reaming path remains in line with the femoral intramedullary canal until reaming is complete. Verify depth under fluoroscopy. Remove the drill bit and guidewire while holding the protection sleeve in place to maintain exposure.



Opening canal with coring drill

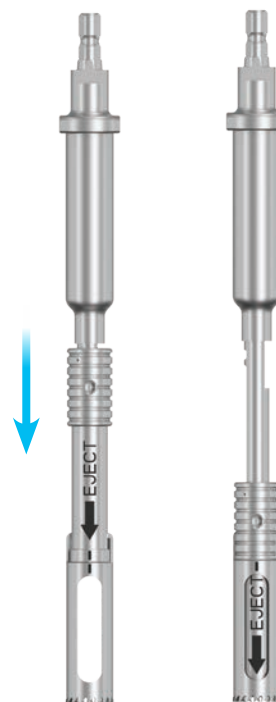

16mm Coring Opening Drill Bit centering piece snapped into forward position

## Opening the Medullary Canal (Cont'd)

Alternatively, an awl may be used to open the medullary canal.

The **Curved Awl** can be used to establish an entry point without the use of the 3.2mm guidewire. Rotate the awl to advance and open the canal. A **Ball-Tip Guidewire, 3.0x1000mm** can be inserted through the cannulation of the Curved Awl.

A **T-Handle 3 Jaw Chuck** may be used to grasp the guidewire during insertion.

Verify depth under fluoroscopy. Remove the T-handle and awl and leave the guidewire in place. Use intramedullary reamers to open the medullary canal to the desired diameter.



Opening canal with awl

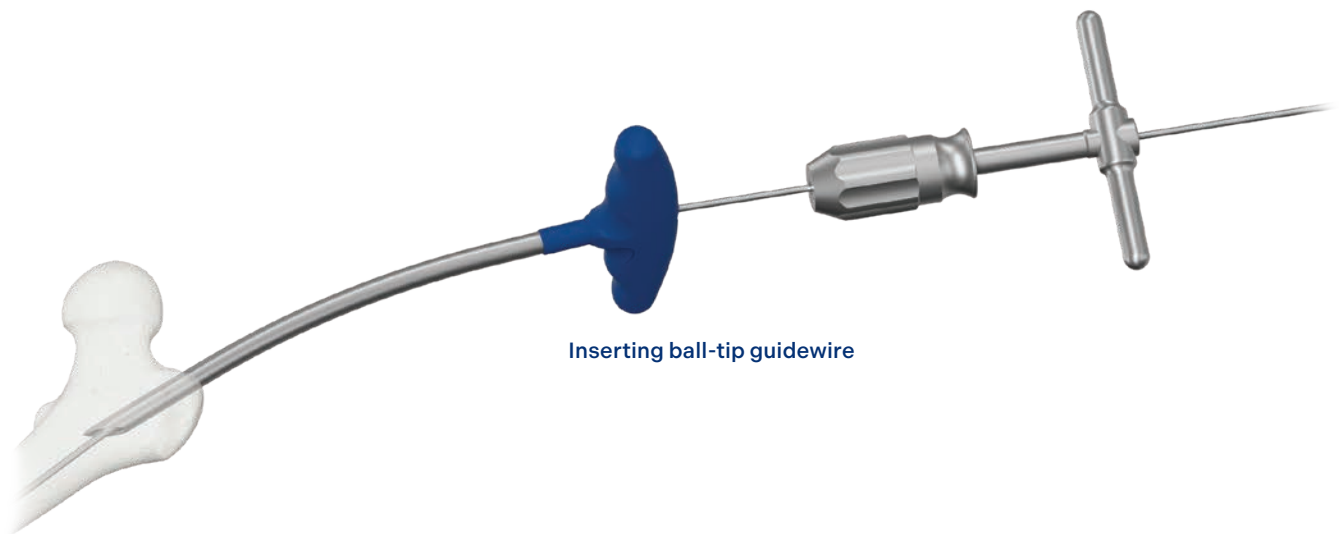

Inserting ball-tip guidewire

**STEP****7**

## Determining Nail Length

Insert the ball-tip guidewire into the medullary canal. The T-Handle 3 Jaw Chuck can be used to grasp the guidewire if necessary. The **Intramedullary Reduction Tool, Hall Connection** may also be used to facilitate passing the guidewire across the fracture site.

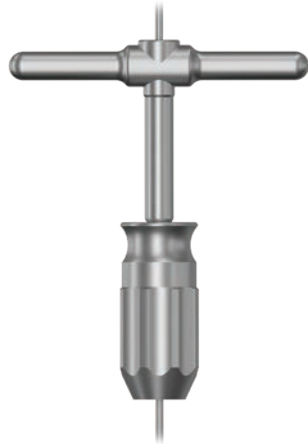

Inserting ball-tip guidewire



Ball-tip guidewire insertion

Ensure the ball-tip guidewire is at the desired distal location in the medullary canal. Connect the Nail Length Gauge to the **Extension, Nail Length Gauge**.

Pass the length gauge assembly over the ball-tip guidewire to the nail entry point until it rests on bone. Determine nail length directly by reading the measurement on the length gauge at the tip of the guidewire. Use fluoroscopy to confirm the position of the length gauge.

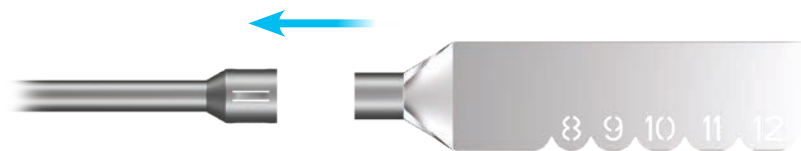

Connecting length gauge instruments



Length gauge extension touching bone



**!** The length gauge requires the use of the 1000mm guidewire.

# Optional: Intramedullary Reaming

Ensure the ball-tip guidewire is at the desired depth in the medullary canal. Confirm fracture reduction using fluoroscopy.

The reamers are modular and can be attached to the **Flexible Reamer Shaft, 470mm, Hall Connection** or **Flexible Reamer Shaft, 620mm, Hall Connection**. Insert the reamer shaft into the **Front Cutting Reamer Head, 8.5-9.5mm** or **Front and Side Cutting Reamer Head, 10-16mm** until it snaps into place.

Ensure the reamer shaft is fully seated into the reamer head prior to insertion over the ball-tip guidewire. If the reamer head will not pass over the ball-tip guidewire, it is not fully seated on the reamer shaft.

Ream the canal by increasing the reamer size in 0.5mm increments using steady pressure. The **Guidewire Pusher** may be used to help ensure the ball-tip guidewire is secure during reaming.

If needed, retract the reamer to clear debris from the canal.

Ream up to 1.5mm greater than the selected nail diameter. Remove the reamer shaft from the intramedullary canal and leave the ball-tip guidewire in place.



Front Cutting Reamer Head, 8.5-9.5mm



Front and Side Cutting Reamer Head, 10-16mm

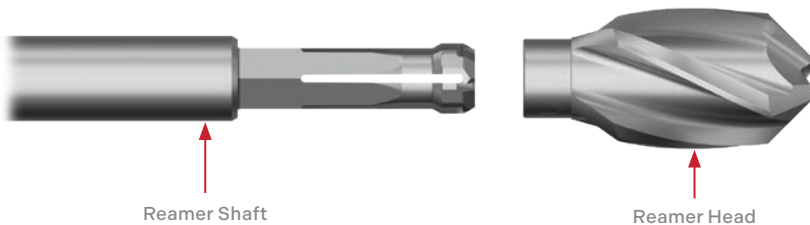

**!** Reamer shaft fingers expand within the reamer head to retain it.

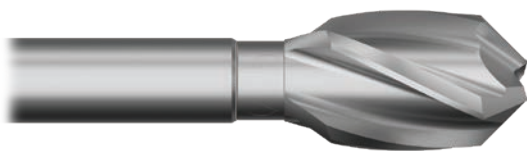

Reamer head fully seated on reamer shaft

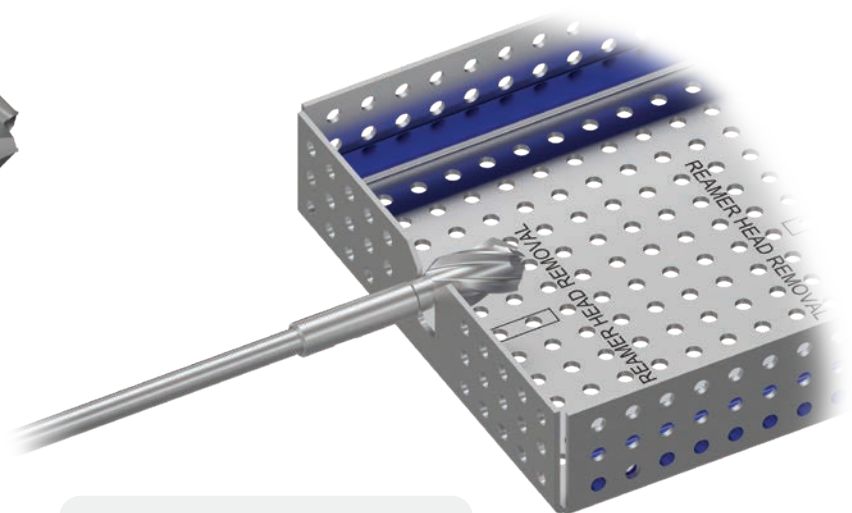

**!** Use the reamer caddy lid to remove the reamer heads.

# Optional: Intramedullary Reaming (Cont'd)

## NAIL ASSEMBLY OVERVIEW

Insert and thread the **Nail Connection Bolt** into the **Insertion Handle**. Once threaded in, the Nail Connection Bolt should be retained within the Insertion Handle.

Attach the selected nail to the Insertion Handle by aligning the tabs on the tip of the Insertion Handle with the notches at the proximal end of the nail.

Attach the T-handle to the **Nail Connection Bolt Driver, Shaft**.

Insert the driver and engage the Nail Connection Bolt; rotate the driver clockwise until the connection is rigid. There should be no toggle between the nail and the Insertion Handle.

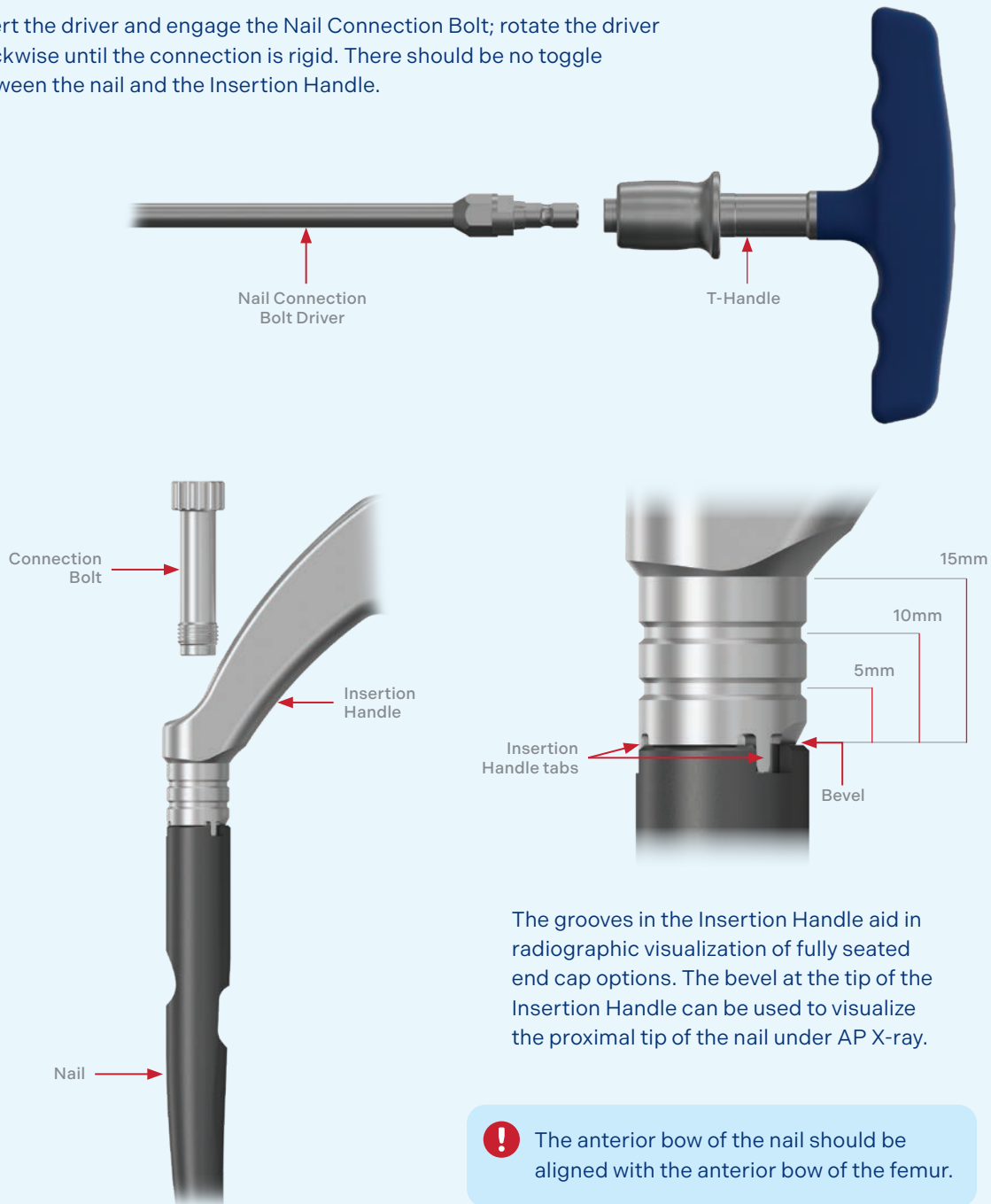

The grooves in the Insertion Handle aid in radiographic visualization of fully seated end cap options. The bevel at the tip of the Insertion Handle can be used to visualize the proximal tip of the nail under AP X-ray.

 The anterior bow of the nail should be aligned with the anterior bow of the femur.

**STEP****8**

## Nail Insertion

The **Impaction Rod, Antegrade** may be threaded into the top of the Insertion Handle.

Insert the nail into the medullary canal by passing the nail over the ball-tip guidewire. Light impaction may be applied using the impaction rod and **Slotted Mallet**. Confirm fracture reduction using fluoroscopy. Insert the nail until the desired depth is reached.

For long nails, rotate the Insertion Handle anteriorly until it reaches the isthmus. As the nail is advanced, rotate the handle laterally for final positioning.

Remove the ball-tip guidewire.



# Nail Insertion (Cont'd)

## AIMING ARM ASSEMBLY

The aiming arm attaches to the Insertion Handle through two alignment pins and a threaded connection knob. Select the aiming arm corresponding to the chosen nail style (125° or 130°). To attach the Aiming Arm to the Insertion Handle, align the alignment pins on the Aiming Arm with the corresponding holes on the Insertion Handle and rotate the connection knob clockwise to tighten the assembly components together.

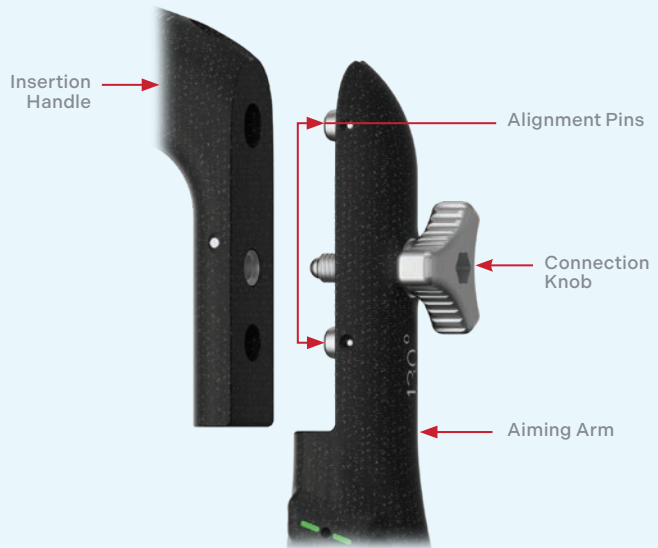

If preferred, the nail connection bolt driver may be used to securely tighten the aiming arm to the Insertion Handle.



Assembled Aiming Arm, 125°



Assembled Aiming Arm, 130°

## STEP 9 Verifying Nail Anteversion

Insert a 3.2mm guidewire into the anteversion check hole on the top of the Insertion Handle.

Confirm position using fluoroscopy. Lateral imaging should be in line with the femoral neck and proximal shaft. Adjust the nail rotation so that radiographic lines on the Insertion Handle are parallel to the nail.

In the lateral X-ray view, the guidewire should be located centrally in the femoral neck and head.



Inserting guidewire through Insertion Handle



Lateral view of guidewire

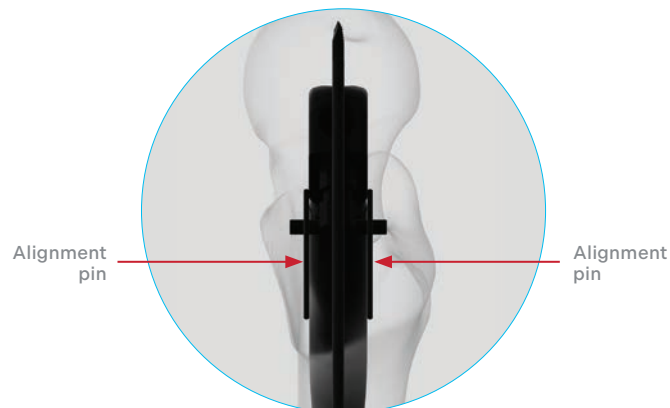

X-ray lateral view of guidewire and alignment pins

# Verifying Nail Anteversion (Cont'd)

## LAG SCREW SLEEVE ASSEMBLY

To assemble the lag screw sleeve assembly, insert the **Trocar, Lag Screw** into the **Wire Sleeve, Lag Screw**. Insert the wire sleeve into the **Driver Sleeve, Lag Screw**. Optionally, a T-handle can be attached to the trocar for ease of insertion. Yellow markings on the instruments indicate they are for lag screw insertion.

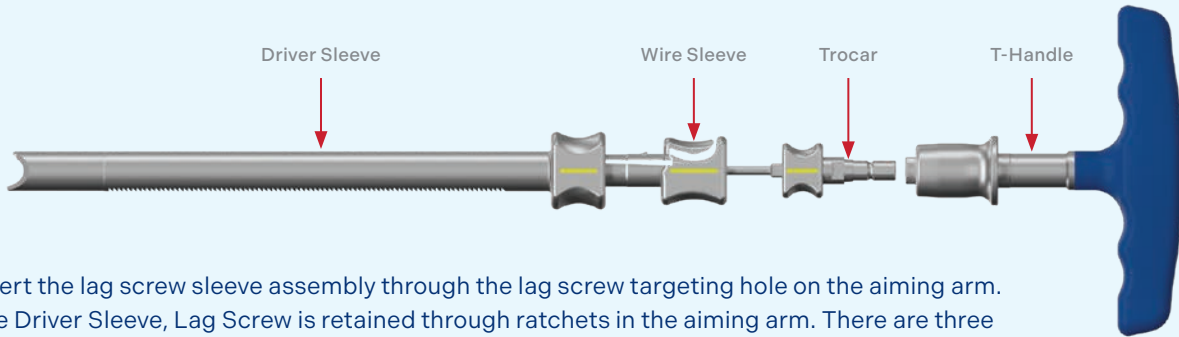

Insert the lag screw sleeve assembly through the lag screw targeting hole on the aiming arm. The Driver Sleeve, Lag Screw is retained through ratchets in the aiming arm. There are three positions on the switch for retention: front position is "LOCK," center position is "INSERT," and back position is "REMOVE." The ratchet paddle can also be used to unlock and slide the driver sleeve.



Inserting driver sleeve assembly into aiming arm

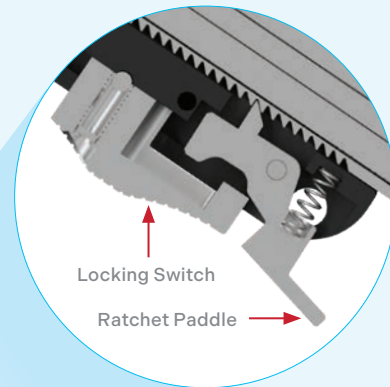

Cross sectional view of aiming arm locking switch and ratchet paddle



REMOVE

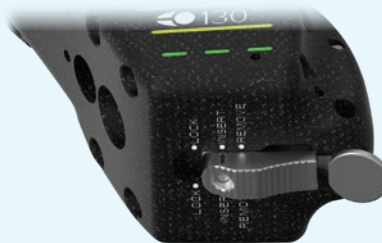

INSERT

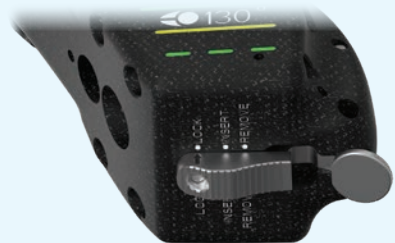

LOCK

## STEP 10

# Guidewire Insertion for Lag Screw

Create a small incision and insert the lag screw sleeve assembly into the skin until the tip reaches the lateral cortical wall. Ensure the switch is in the "LOCK" position to secure the sleeve in place.

Remove the trocar and pass a **3.2mm Guidewire, Threaded Drill Point, 400mm** or **3.2mm Guidewire, Drill Point, 400mm** through the Wire Sleeve, Lag Screw until bone is reached. Advance the guidewire into the femoral head until the desired position is reached.

Verify guidewire position using fluoroscopy in both AP and lateral views to obtain the desired depth in subchondral bone in the femoral head. The guidewire should be centered in the femoral head and neck on both the AP and lateral views. Ideal guidewire placement into the femoral head should minimize tip-apex distance.



Inserting guidewire



Tip-apex distance



Guidewire insertion for lag screw or hip fastener

**!** Do not over-ratchet or strike the lag screw sleeve assembly as this may deform the aiming arm.

# Optional: Anti-Rotation Wire Insertion

In unstable fractures, additional guidewires may be inserted to help prevent rotation and add stability.

There are six anti-rotation wire options on the aiming arm: 3 anterior and 3 posterior. The locations for the anterior wires are displayed below: inferior, superior, and superior oblique. If using one wire, the superior anterior wire is recommended.

Make a small incision and place the **Anti-Rotation Wire Sleeve** into contact with bone. Rotate the sleeve 90° to lock into place in the aiming arm.

Advance a 400mm guidewire through the sleeve into bone and into the femoral head. Confirm the positioning using fluoroscopy.

Repeat for additional guidewires as needed.

*Note: The superior and superior oblique wires cannot be used together.*

*Note: It is recommended to insert the anti-rotation wire prior to insertion of the AUTOBAHN™ Hip Fastener.*

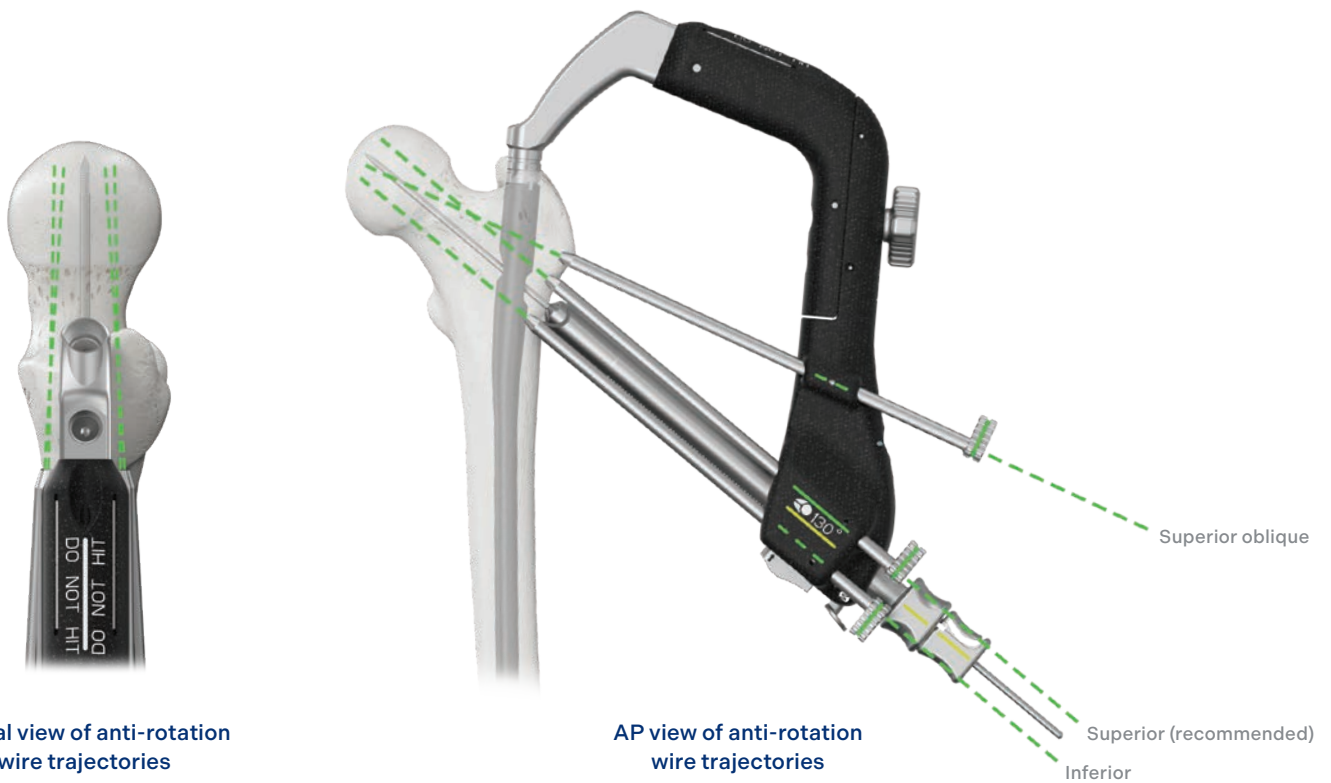

Lateral view of anti-rotation wire trajectories

AP view of anti-rotation wire trajectories



Unlocked

Locked

## STEP 11 Lag Screw Preparation

Press the release lever on the Wire Sleeve, Lag Screw and pull back the wire sleeve from the Driver Sleeve, Lag Screw to the end of the 400mm guidewire. Measurement of lag screw or hip fastener length can be read on the proximal end of the wire sleeve. Measurement is from the tip of the guidewire to the tip of the driver sleeve.

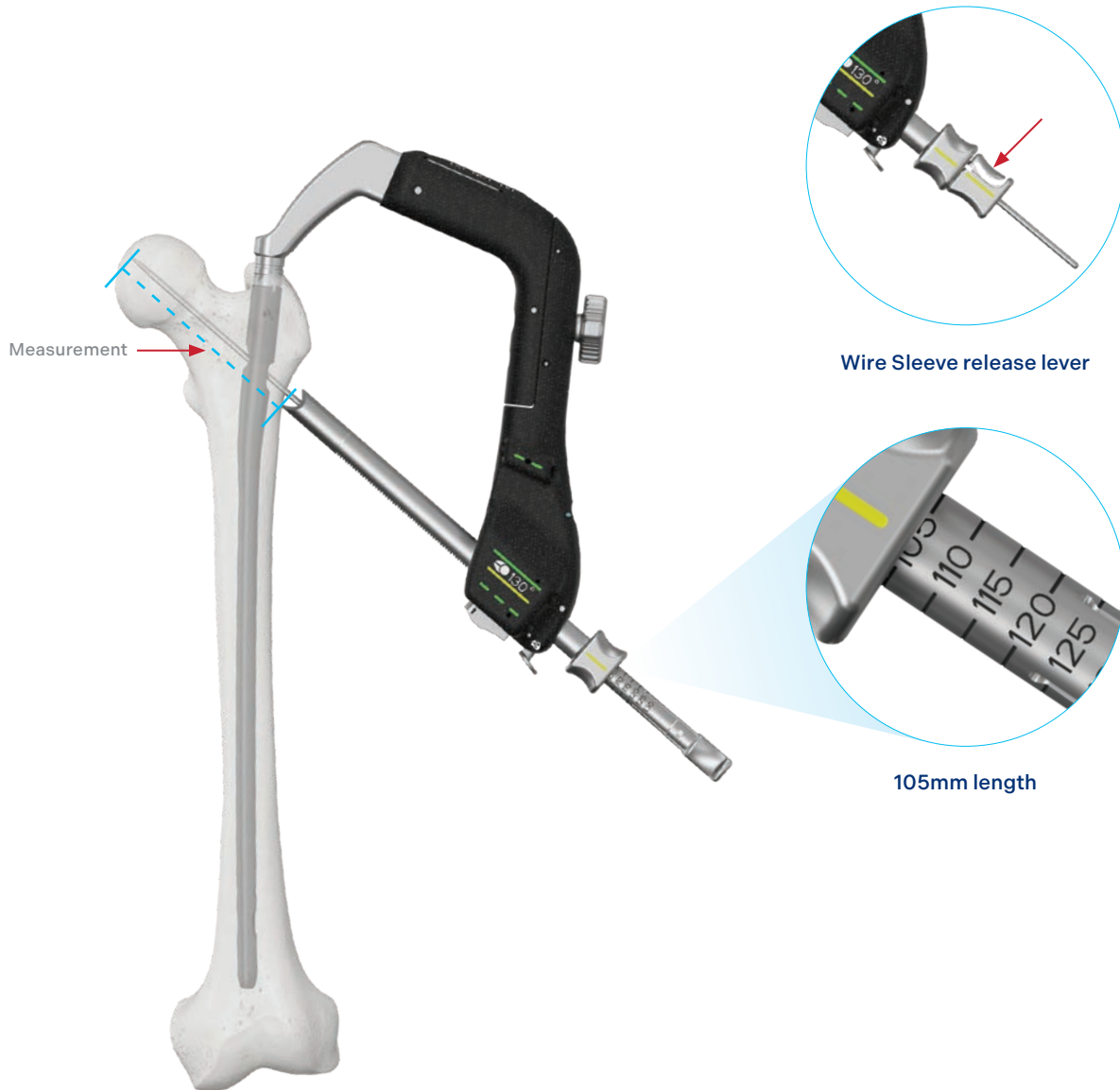

Measuring lag screw length

**!** The Wire Sleeve, Lag Screw is used to measure lag screw or hip fastener length. The drill and lag screw measurements correspond to the tip of the guidewire.

**!** Screw lengths are indicated by the number on each line.

# Lag Screw Preparation (Cont'd)

## PROXIMAL FIXATION OPTIONS

### *Lag Screw*

The AUTOBAHN™ Lag Screw is the standard proximal fixation option.

For lag screw drilling, use the **Lag Screw Stepped Drill Bit, 10mm** (yellow band).



### *Hip Fastener*

The AUTOBAHN™ Hip Fastener with Helical Hook Technology can be used as an alternative to the lag screw. For hip fastener drilling, use the **Hip Fastener Stepped Drill Bit, 10mm** (orange band).

It is recommended to insert the anti-rotation wire prior to inserting the hip fastener (refer to Anti-Rotation Wire Insertion section).

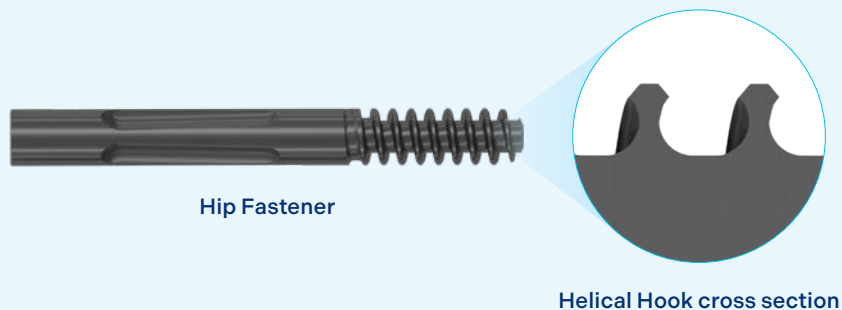

## Lag Screw Preparation (Cont'd)

For proximal fixation drilling, slide the **Drill Stop, Lag Screw** over the back of the Lag Screw Stepped Drill Bit, 10mm (yellow band) or Hip Fastener Stepped Drill Bit, 10mm (orange band) until the desired screw length is visible in the drill stop window. Drill over the guidewire to the appropriate depth on the drill stop. Confirm drill depth using fluoroscopy.

If desired, a tap may be used with the T-handle and **Lag Screw Tap**. The Lag Screw Tap is compatible with the lag screw and hip fastener. In dense bone, tapping may be necessary prior to screw insertion.



105mm drill stop

Drilling with lag screw drill

## STEP 12 Inserting the Lag Screw

Insert and thread the **Retention Rod, Lag Screw Driver** into the **Lag Screw Driver**. Once the retention rod threads through the Lag Screw Driver, it will be retained. Select the appropriate length lag screw or hip fastener and secure the lag screw or hip fastener to the Lag Screw Driver with the retention rod.

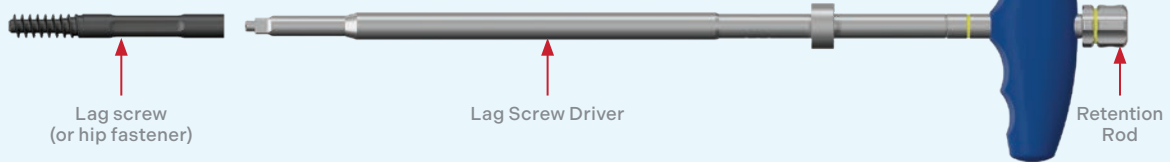

Advance the lag screw or hip fastener and Lag Screw Driver over the guidewire. Confirm placement using fluoroscopy.

When the appropriate depth is reached, ensure the Lag Screw Driver handle is parallel with or perpendicular to the aiming arm, for static locking or controlled collapse.

### Interfragmentary Compression

If compression across the fracture(s) is desired, ensure the lag screw or hip fastener is in the correct position and is not in contact with the set screw within the nail.

Use the locking feature on the aiming arm to prevent the driver sleeve from advancing during compression.

Attach the **Compressor** by engaging the end of the driver sleeve and the compression ring on the Lag Screw Driver.

Compress the handles until the desired amount of compression is achieved; verify compression under fluoroscopy. Tighten the set screw and remove the Compressor.

Use care to avoid deforming the aiming arm as the Compressor is powerful.

**!** The Compressor remains connected to the driver sleeve and driver while applying compression.

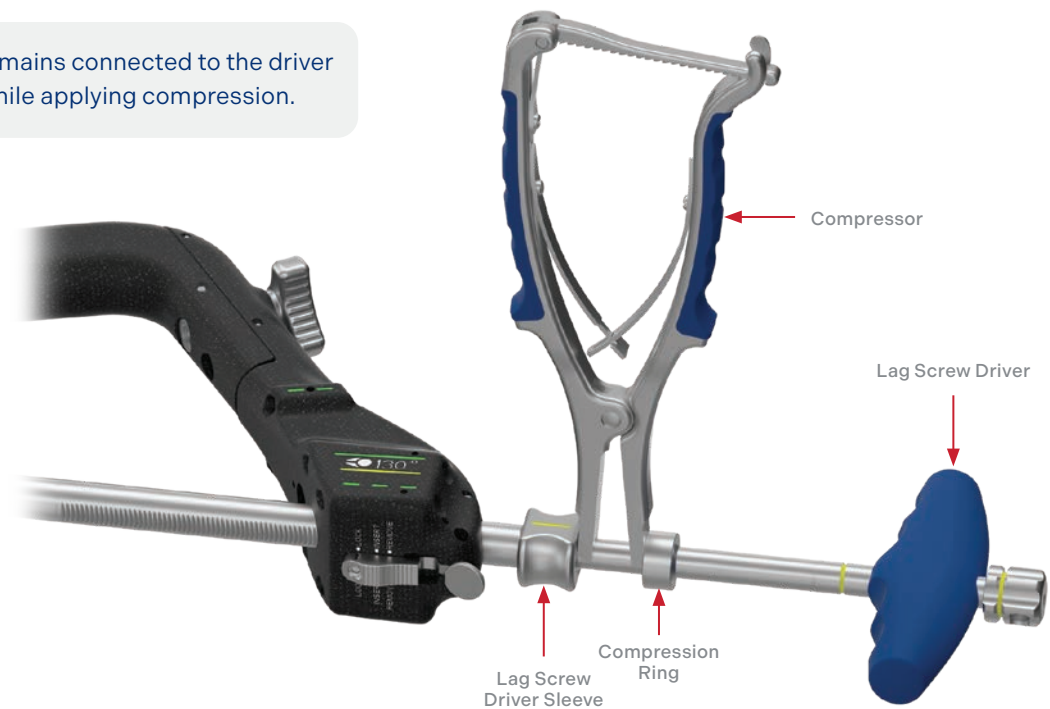

Proximal femur fracture compression

## STEP 13 Engaging the Set Screw

The handle of the Lag Screw Driver must be parallel or perpendicular to the aiming arm to ensure that the set screw will tighten into one of the four grooves on the lag screw or hip fastener.

To lock the construct, attach the **T40 Set Screw Driver, Hinged** to the T-handle and insert through the proximal hole on the Insertion Handle. Tighten the set screw until it is firmly against the lag screw or hip fastener to prevent sliding of the lag screw or hip fastener within the nail. To verify the set screw is in the correct position, attempt to rotate the Lag Screw Driver. If the Lag Screw Driver will not turn, the set screw is correctly engaged in the groove on the lag screw or hip fastener.

For controlled collapse, reverse the set screw one quarter rotation to allow limited sliding but not rotation of the construct. Detach the Lag Screw Driver from the lag screw or hip fastener. Remove the guidewire.



## STEP 14

# Distal Locking Screw Insertion

## Short and Intermediate Nail Locking

Confirm reduction of the fracture using fluoroscopy. Create a stab incision to insert the distal locking screw.

### 5mm TROCAR SLEEVE ASSEMBLY

The trocar sleeve assembly is designed to facilitate insertion and retention. Blue markings on the instruments indicate they are for 5mm screw insertion.

Assemble the 5mm trocar sleeve by inserting the **Trocar, 4.2mm** into the **Drill Sleeve, 4.2mm**. Insert the drill sleeve into the **Driver Sleeve, 5mm** and rotate the drill sleeve clockwise to tighten.

The driver sleeve has cutouts near the distal tip to visualize screw heads on fluoroscopy.

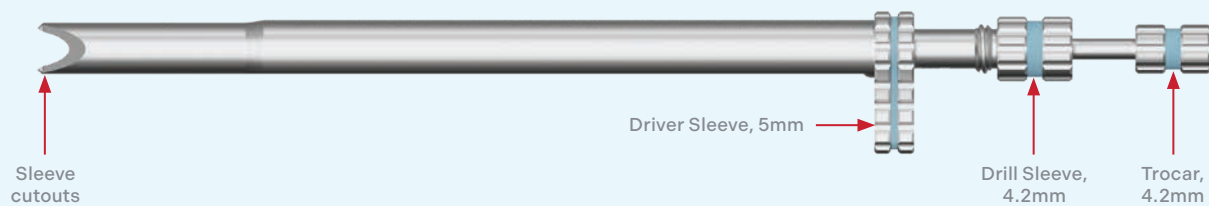

For static locking, use the 5mm distal locking hole.

Insert the trocar sleeve assembly by aligning the black line on the sleeve with the white line on the aiming arm near the 5mm hole. Once inserted to the desired depth, rotate the trocar sleeve assembly 180° to allow visualization of the cutout using AP fluoroscopy.



Inserting trocar sleeves

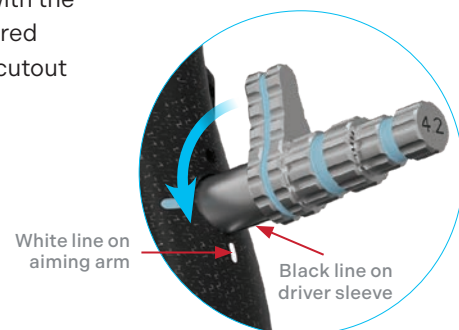

Unlocked

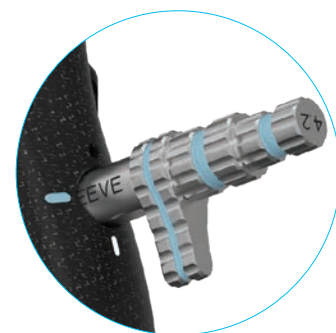

Locked

# Drilling

Remove the trocar and insert the **4.2mm Calibrated Drill Bit, 330mm, Short Flutes** into the drill sleeve and drill to the desired depth. Measure hole depth using the calibrated drill or **Depth Gauge, 5mm, Long**.

Remove the drill bit and drill sleeve.



Drilling for 5mm screw

## SCREW LENGTH MEASUREMENT

The 4.2mm calibrated drill bit and depth gauge, 5mm are used to measure hole depth for full thread engagement in the far cortex using 5mm screws.

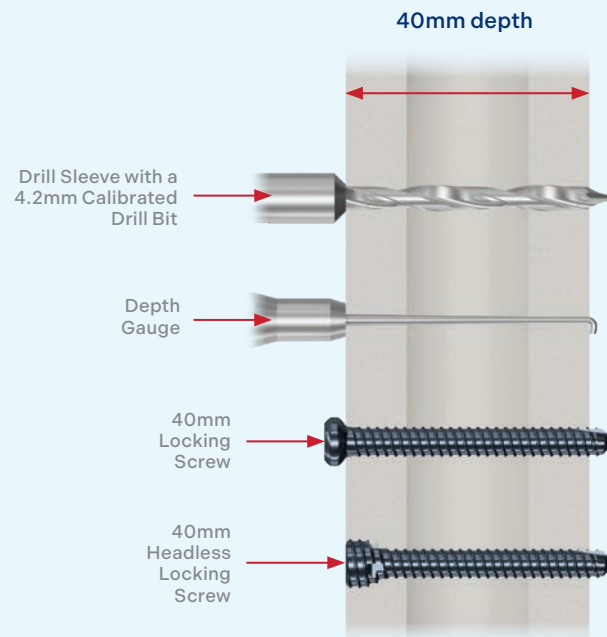

## Drilling (Cont'd)

### SCREW LENGTH MEASUREMENT USING THE CALIBRATED DRILL BIT

To measure using the calibrated drill, position the tip of the drill bit at the intended final location for the tip of the 5mm locking screw. Determine the measurement directly at the back of the drill sleeve.

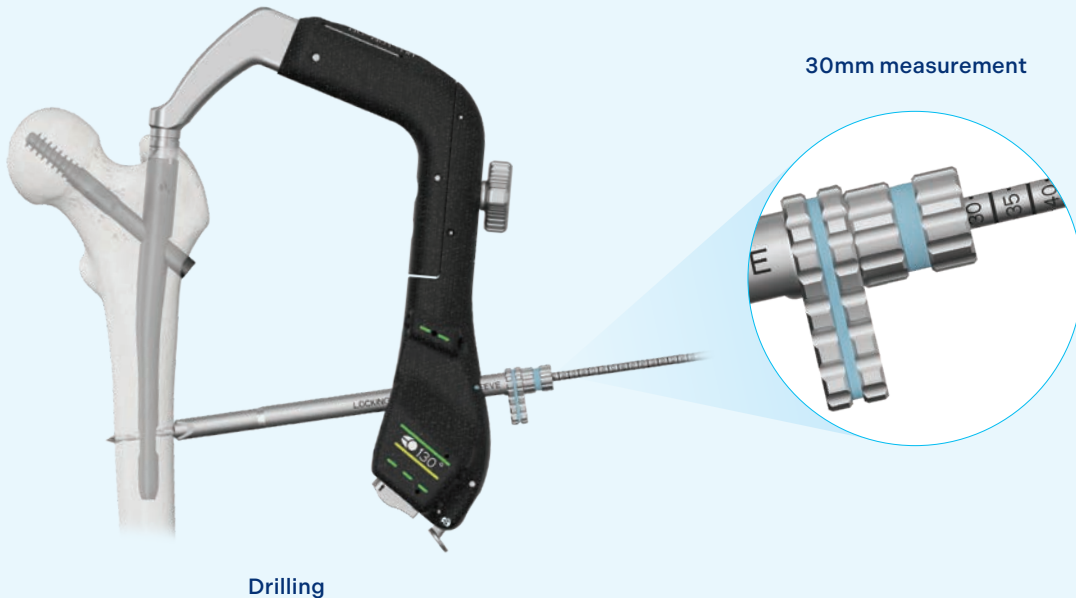

### SCREW LENGTH MEASUREMENT USING THE DEPTH GAUGE

To measure using the depth gauge, remove the drill bit and drill sleeve. Ensure the driver sleeve is touching bone. Insert the depth gauge stick through the driver sleeve. Extend the tip to the desired position, or through the far cortex, and retract until the hook engages the far cortex. Determine screw length by reading the markings directly at the back of the driver sleeve.

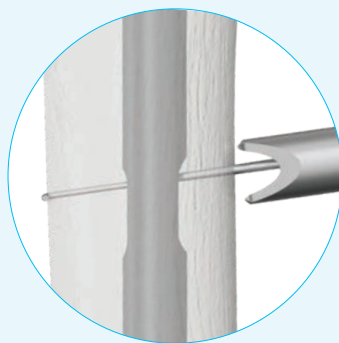

Hooking far cortex with depth gauge

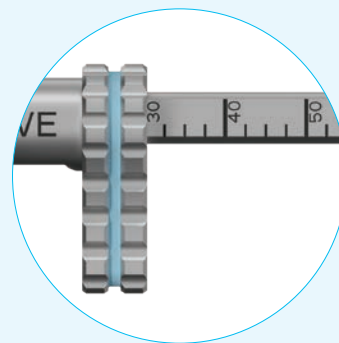

30mm measurement

# Inserting Locking Screws

Select the appropriate 5mm locking screw. Use the **T30 5mm Screwdriver for Power, Long** to insert the selected 5mm locking screw through the driver sleeve. A **Retention Rod, T30 5mm Screwdriver for Power, Long** may be used for screw retention. Insert the locking screw until flush with the near lateral cortex. Confirm screw length using fluoroscopy. Remove the driver and driver sleeve.

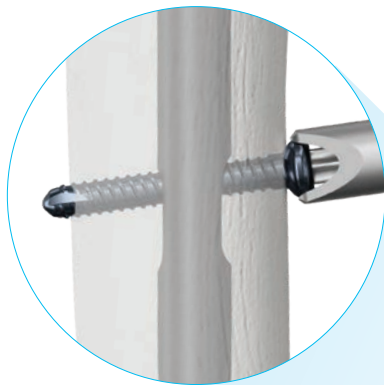

Final screw position



Inserting locking screw

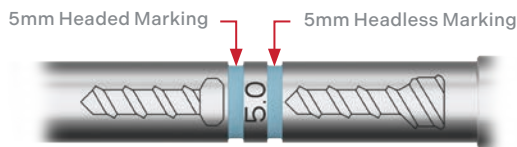

## SCREW RETENTION

All locking screws can be retained during insertion.

Insert the retention rod into the **T30 Screwdriver for Power, Long**. Rotate the retention rod clockwise to capture the internal screw threads.

After final placement of the screw, remove the T30 screwdriver from the screw by detaching the quick-connect handle and rotating the knob of the retention rod counterclockwise. An extraction pin wrench may be used.

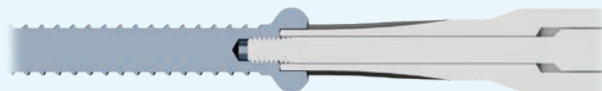

Cross-section view of retention rod in screw



T30 screwdriver and retention rod

# Short Nail Final Construct



# Long Nail Freehand Locking

Distal locking is performed freehand using the perfect circle technique. Confirm reduction of the fracture before placing screws.

Select the desired lateral-medial (LM) distal hole on the nail. Align the C-arm so that the hole is a perfect circle under fluoroscopy. Place a scalpel blade on the skin over the center of the desired hole. Verify position of the blade under fluoroscopy and create a small incision.

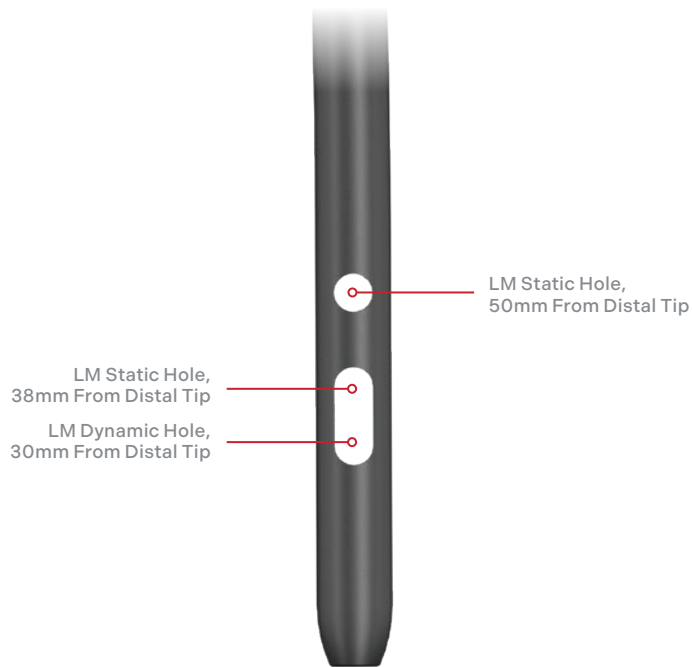

Distal hole options



Identifying incision location

# Drilling and Measurement

Insert the **4.2mm Drill Bit, 170mm, Short Flutes** into the incision until bone is reached. Confirm the starting point with fluoroscopy. Angle the drill bit perpendicular to the nail hole and drill through both cortices. Confirm drill bit position under fluoroscopy.

Screw measurement can be performed with the **Direct Read Depth Gauge, 5mm** or a **Depth Gauge, 5mm, Short**.

To use the direct read depth gauge, insert the depth gauge over the drill bit until bone is reached. Read the marking on the gauge at the back of the drill bit. Remove the gauge.

Alternatively, to measure depth, remove the drill bit. Insert the depth gauge until bone is reached. Extend the hook completely through the femur and retract until the hook engages the far cortical wall. Determine the length by reading the measurement on the gauge. Remove the depth gauge.



Identifying drill starting point

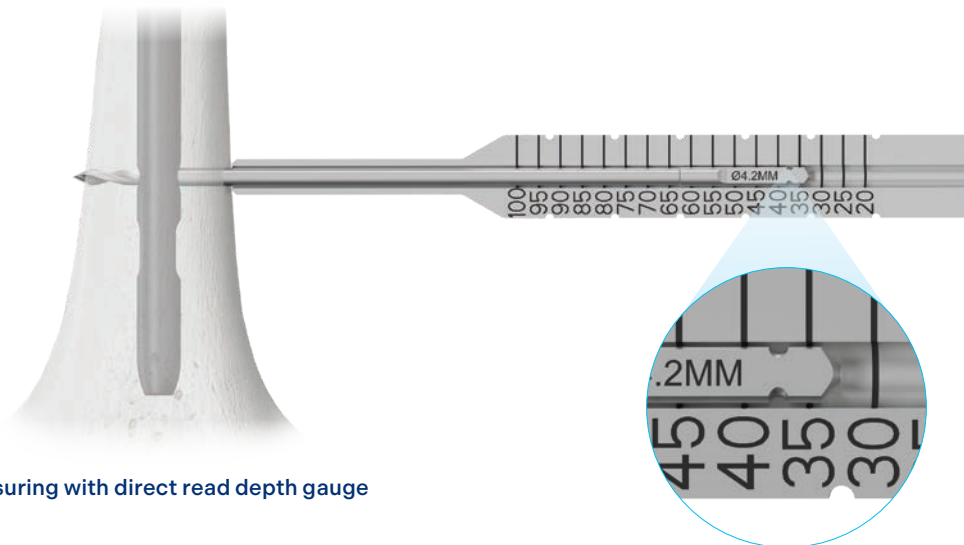

Measuring with direct read depth gauge

32.5mm measurement

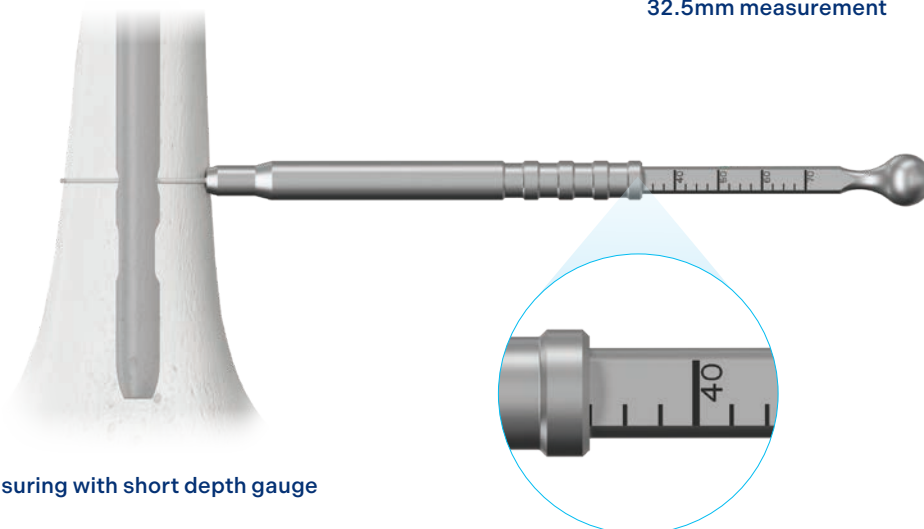

Measuring with short depth gauge

32.5mm measurement

## Inserting Distal Screw

Insert the selected 5mm locking screw using the **T30 Screwdriver for Power, Short**.

Confirm screw length and position under fluoroscopy. Remove the driver. Repeat steps for other locking screws. A **Retention Rod, T30 Screwdriver for Power, Short** may be used for screw retention.



Inserting distal locking screw in long nail

# Long Nail Distal Targeting

The AUTOBAHN™ Distal Targeting System can be used for targeting of distal holes in AUTOBAHN™ trochanteric long nails.

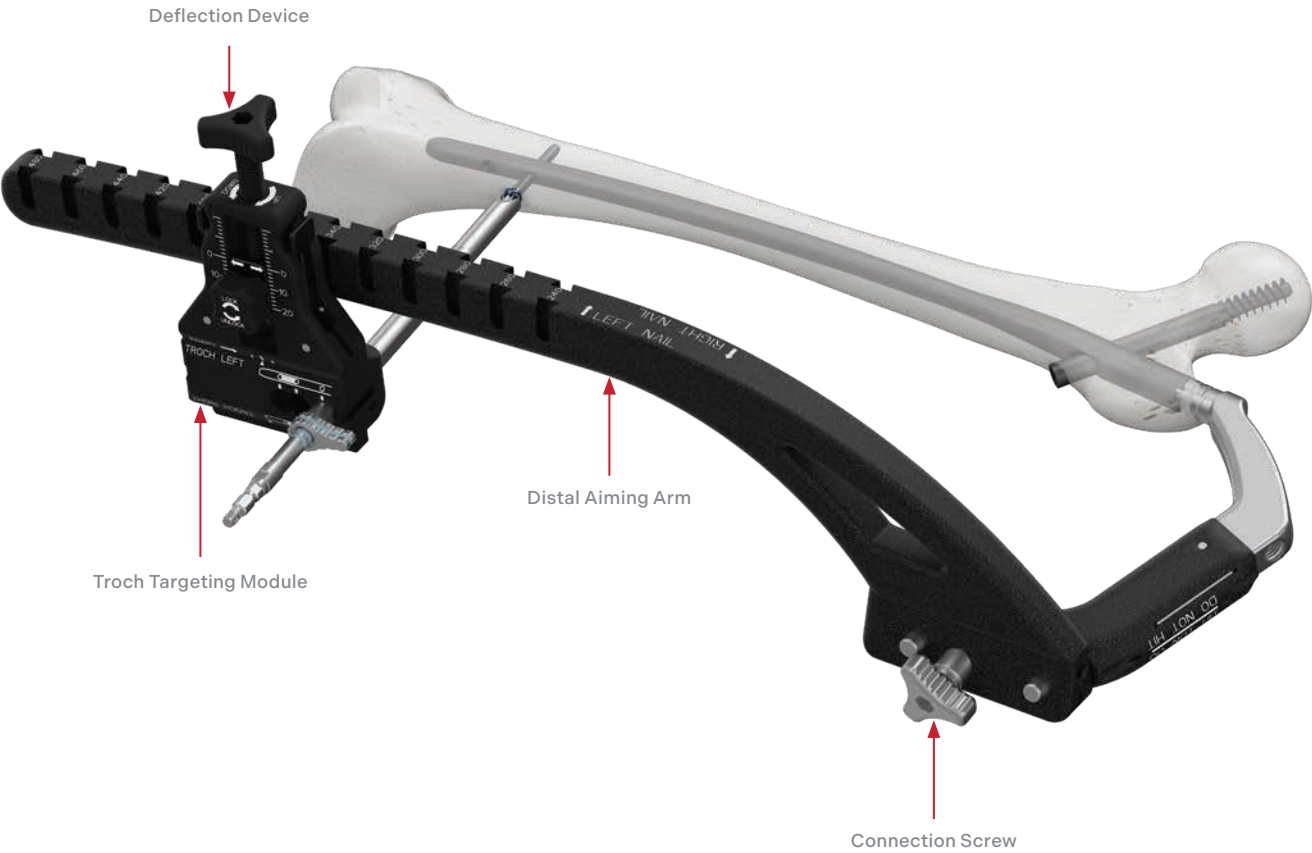

# Long Nail Distal Targeting (Cont'd)

## DISTAL TARGETING ASSEMBLY

To assemble the distal targeter, attach the **Deflection Device, Distal Targeter** to the **Distal Aiming Arm** by slotting the alignment piece into the corresponding dovetail on the aiming arm and tightening the connection knob clockwise until hand tight. Ensure the deflection device is on the correct side of the nail for the nail orientation (left/right) and in the correct slot for the corresponding nail length.

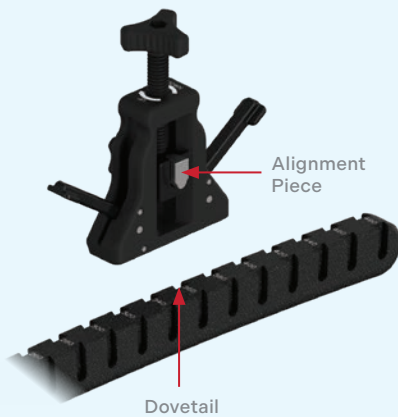

Inserting deflection device into Distal Aiming Arm

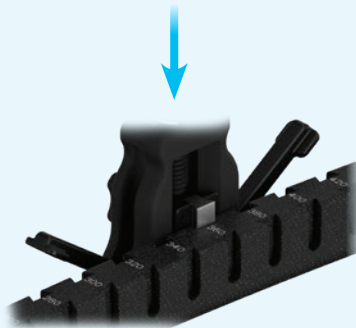

Dovetail alignment

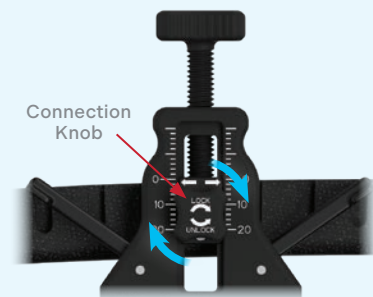

Rotating connection knob to lock

Insert the **Troch Targeting Module** into the bottom slot of the deflection device. Ensure the module is inserted in the correct orientation for targeting the correct nail (left troch/right troch). The module is retained through a snap feature and is still free to move side to side.

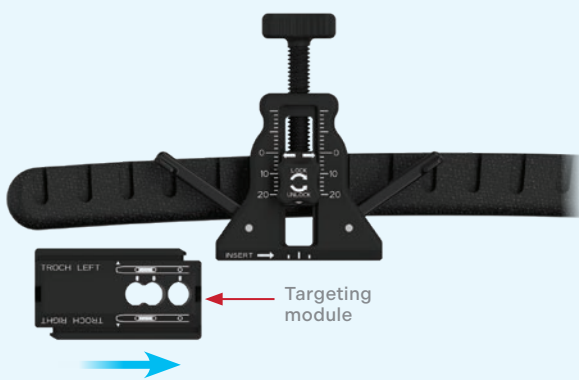

Inserting targeting module

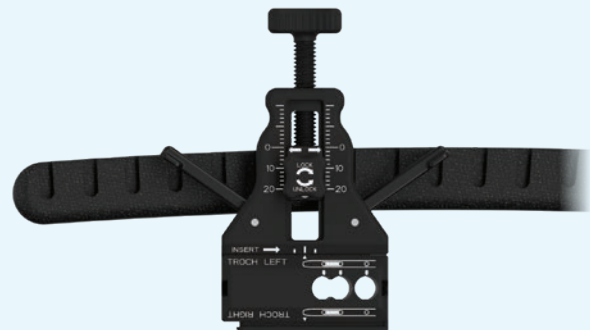

Targeting module and deflection device assembly

# Long Nail Distal Targeting (Cont'd)

## DISTAL TARGETING ASSEMBLY (CONT'D)

The Distal Aiming Arm attaches to the Insertion Handle through two alignment pins and a threaded **Distal Targeter Connection Screw**. Align and attach the aiming arm to the Insertion Handle and rotate the connection screw clockwise to tighten.



# Distal Targeting Preoperative Alignment Verification

On the back table, slide the Distal Aiming Arm assembly into the calibration mount on the graphic case.

Insert the **Distal Targeting Alignment Shaft** into the desired targeting hole on the targeting module.

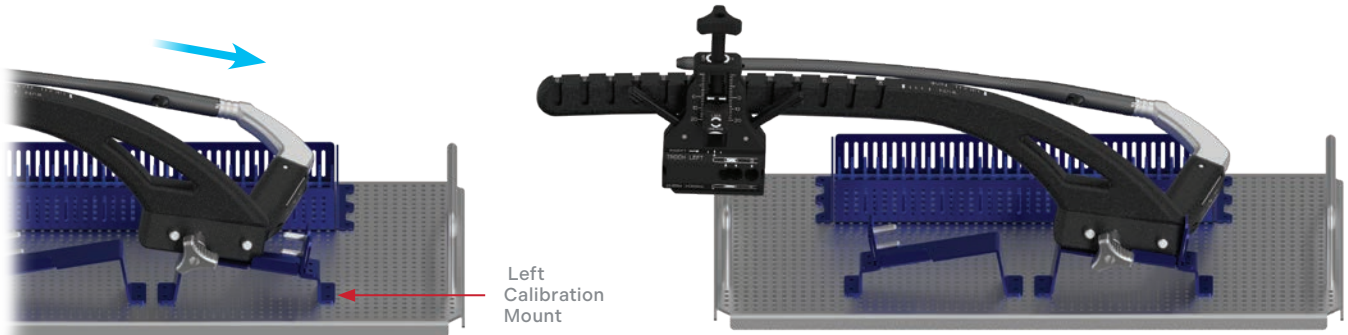

Slide Distal Aiming Arm assembly onto calibration mount

Distal Aiming Arm assembly on calibration mount

Adjust the targeting module horizontally to align the shaft in the inferior/superior direction. Adjust the deflection device vertically using the adjustment knob until the shaft is aligned in the anterior/posterior direction. The shaft should now easily slide into the distal troch nail hole.

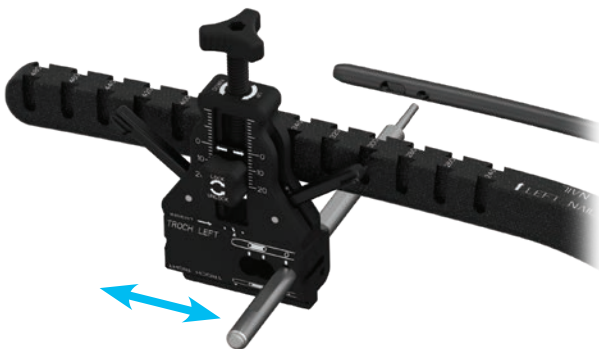

Adjusting horizontally

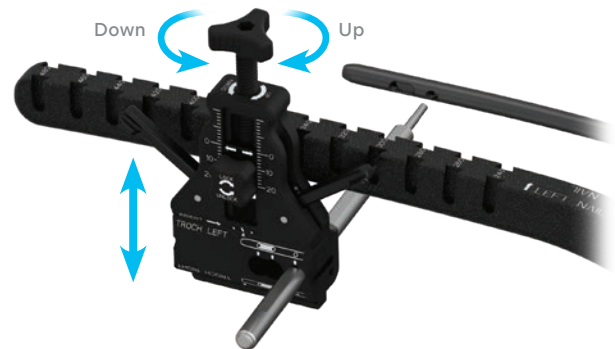

Adjusting vertically

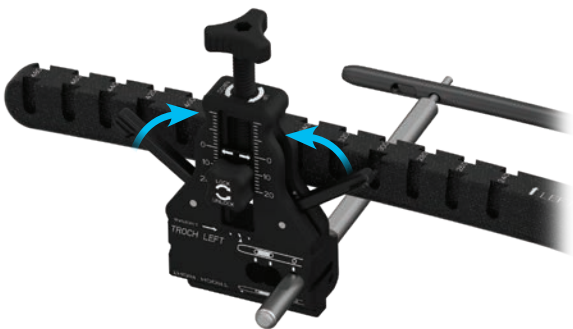

Locking horizontally

Once the shaft is aligned through the targeted hole, squeeze the two lock levers towards the center to lock the module horizontally. These locks should remain in the upright and locked position for the remainder of the procedure.

Remove the alignment shaft and detach the Distal Aiming Arm from the Insertion Handle.

The Distal Aiming Arm assembly can be stored on the calibration mount until needed during the procedure.

# Distal Targeting C-Arm Positioning

Intraoperatively, when ready for distal locking, attach the Distal Aiming Arm assembly to the Insertion Handle. Align and attach the aiming arm to the Insertion Handle and rotate the connection screw clockwise to tighten.

Insert the 5mm trocar sleeve assembly into the targeting module and down to skin. Rotate the sleeve 90° to retain the sleeve assembly.

## C-Arm Positioning

Slide the C-arm down from the proximal femur lateral position, and maintain the same angled orientation to the femoral shaft. The C-arm should be approximately 30° oblique from perpendicular to the femur.

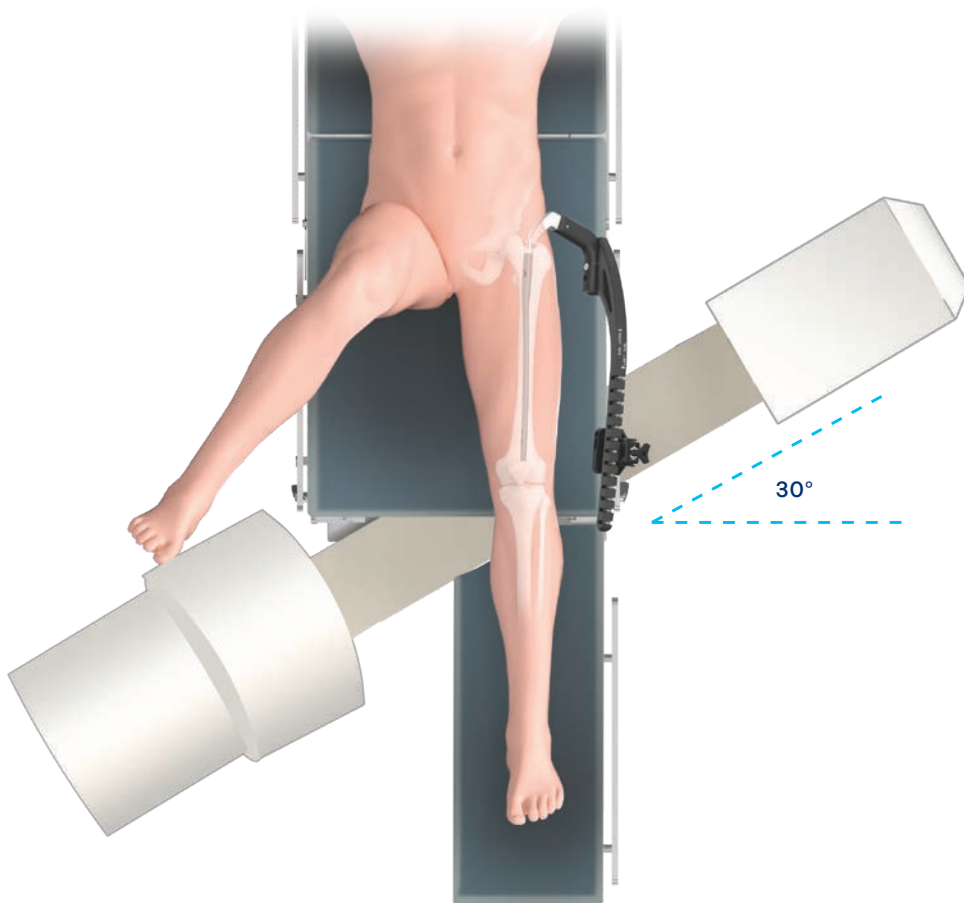

C-arm oblique lateral positioning

# Distal Targeting C-Arm Adjustment

## C-Arm Orbit Adjustment

Rotate the C-arm orbitally to approximately the same plane as the nail and trocar sleeve assembly. Confirm with fluoroscopy that the nail and trocar assembly are within and centered in the X-ray image.

To align the orbit of the C-arm for correct imaging, the nail tip and trocar sleeve must be parallel. Adjust the C-arm until this position is achieved.

If the tip of the nail and trocar sleeve point down (forming a "V"), the X-ray tube needs to be rotated up.

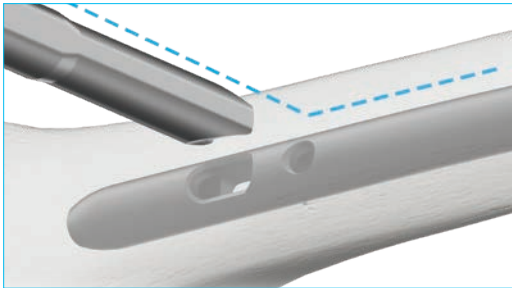

**Nail and trocar sleeve form V**

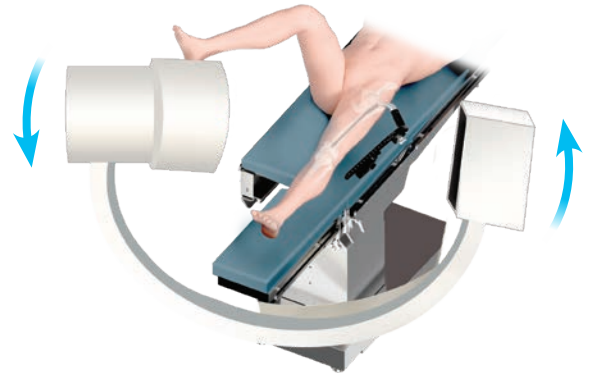

**Rotating C-Arm up  
(X-ray tube too low)**

If the tip of the nail and trocar sleeve point up (forming an inverted "V"), the X-ray tube needs to be rotated down.

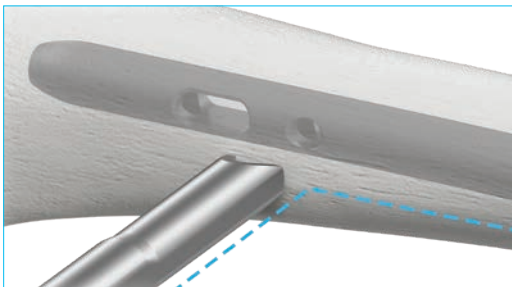

**Nail and trocar sleeve form inverted V**

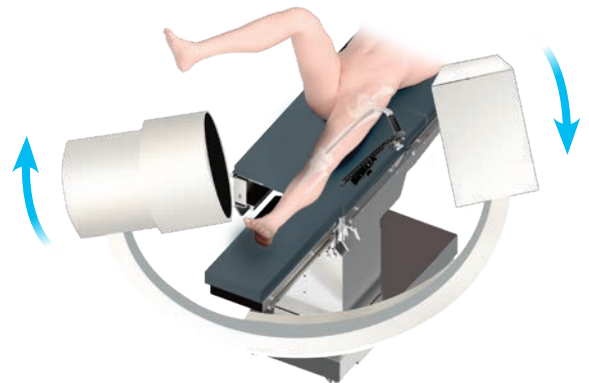

**Rotating C-Arm down  
(X-ray tube too high)**

Adjust the C-arm until the tip of the nail and trocar sleeve are parallel on the image.



**Nail and trocar sleeve are parallel**

# Distal Targeting Deflection Adjustment

## Deflection Device Height Adjustment

Once the tip of the nail and trocar sleeve are parallel on the image, the sleeve may be targeting above or below the nail due to nail deflection post insertion.

Adjust for AP deflection using the adjustment knob on the deflection device. Rotate clockwise to raise the sleeve anteriorly, or counterclockwise to lower the sleeve posteriorly. Adjust until the sleeve and nail are collinear.

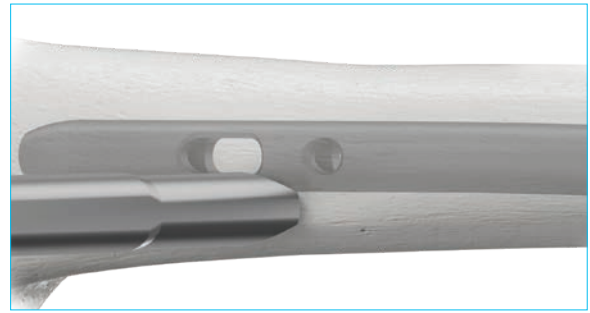

Nail and 5mm sleeve are NOT collinear

**!** Each rotation of the knob adjusts the height by 2mm. The nail diameter may be used as a reference to calculate the approximate amount of height adjustment needed.

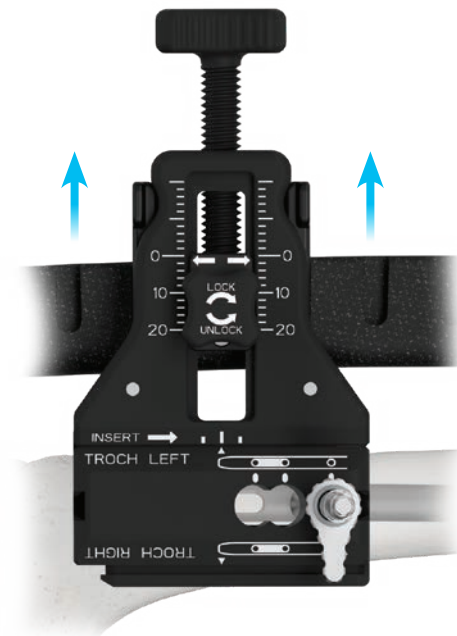
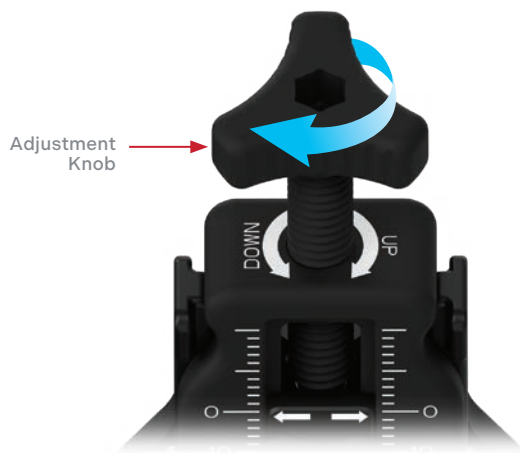

Adjusting up



Nail and 5mm sleeve are collinear

# Distal Targeting Distal Locking

Once the trocar sleeve assembly is correctly positioned, create a small incision. Unlock and insert the trocar assembly into the skin until the tip reaches the lateral cortex. Rotate the sleeve 90° to lock into place. Confirm under fluoroscopy the sleeve is still collinear with the nail after inserting and locking.

Remove the trocar. Insert the 4.2mm calibrated drill bit into the drill sleeve and drill to the desired depth. Measure hole depth using the calibrated drill or depth gauge.

Select the appropriate locking screw. Use the T30 screwdriver to insert the selected 5mm locking screw through the driver sleeve. Insert the locking screw until flush with the near lateral cortex. Confirm screw length using fluoroscopy. Remove the driver and driver sleeve. Refer to the Short and Intermediate Nail Locking section for full detailed locking screw instructions.

For additional screws, repeat the C-arm alignment and height adjustment described in the previous steps. Repeat steps for locking screw insertion. Remove the trocar sleeve from the targeting module. Remove the Distal Aiming Arm from the Insertion Handle by rotating the connection screw counterclockwise to loosen.



# Long Nail Final Construct

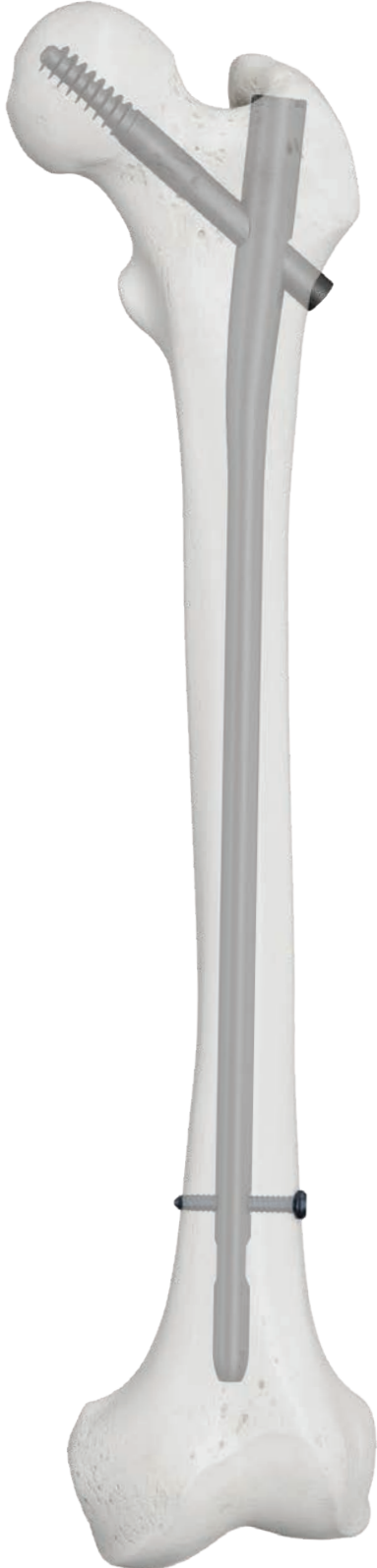

## STEP 15 Insertion Handle Removal

Attach the nail connection bolt driver to a quick-connect handle. Insert the nail connection bolt driver into the Insertion Handle and engage the nail connection bolt. Rotate the bolt driver counterclockwise to loosen. Remove the bolt and the Insertion Handle.

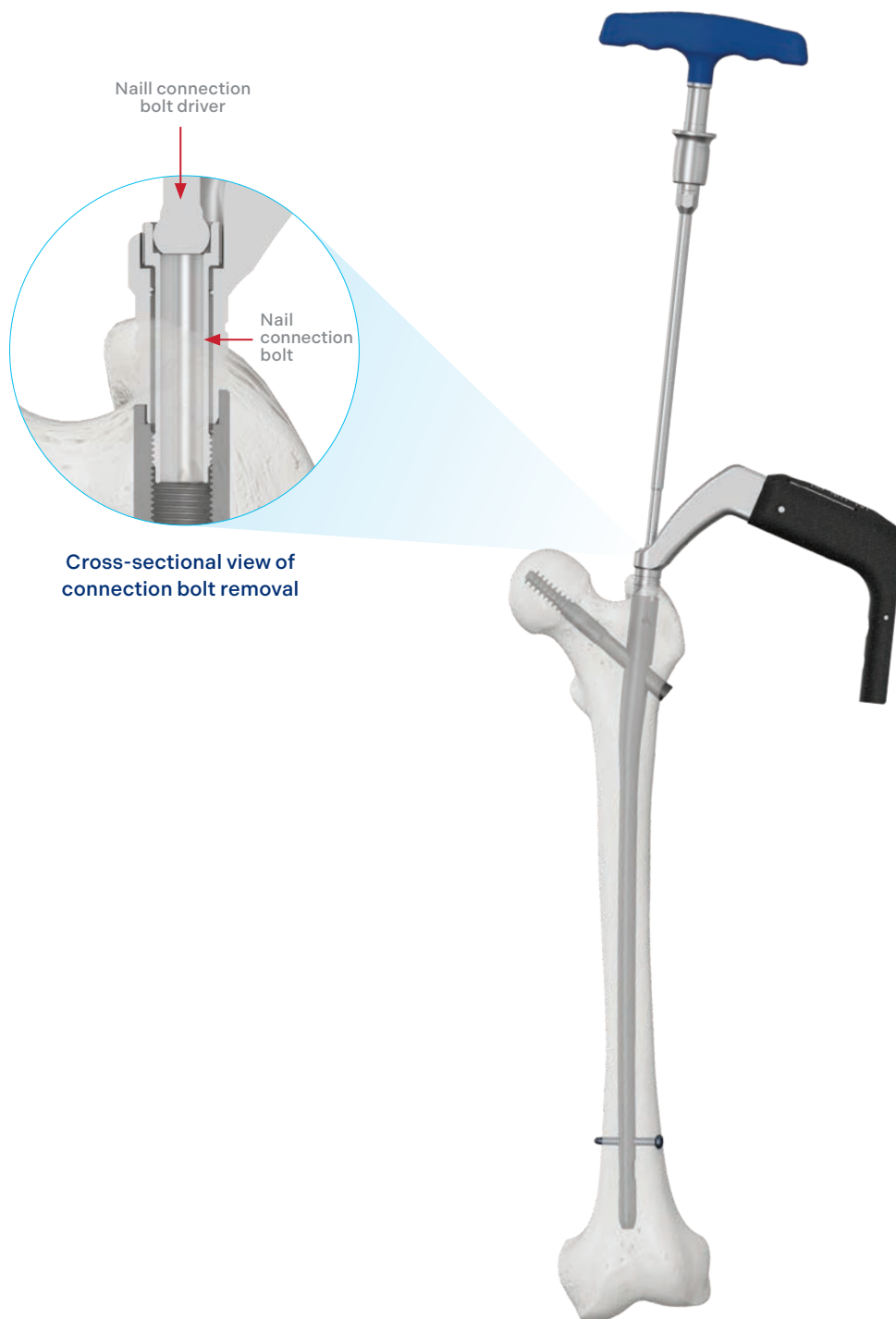

Cross-sectional view of connection bolt removal

Connection bolt removal

## Optional: End Cap Insertion

An end cap may be used to help prevent bony ingrowth into the proximal end of the nail or to extend the nail length.

Using the Lag Screw Driver, insert the appropriate end cap over the 3.2mm guidewire to help with alignment. Rotate the driver clockwise to tighten the end cap to the nail. Remove the Lag Screw Driver.

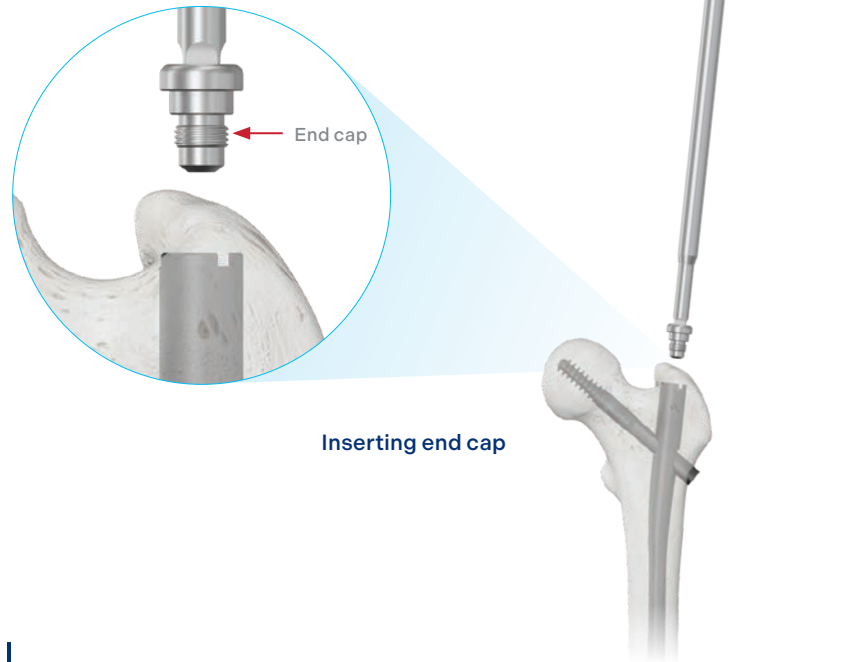

## Optional: Nail Removal

### Removing Intact Nails

If applicable, use the Lag Screw Driver to remove the end cap. Use the T40 screw driver to loosen the set screw.

To remove the lag screw or hip fastener, attach the Lag Screw Driver using the retention rod. Remove any bony ingrowth and re-engage the driver. Rotate the Lag Screw Driver counterclockwise until the device is removed.

Thread the **Nail Extraction Bolt** in the nail with the distal screws in place to help prevent nail rotation or subsidence.

Remove distal locking screws by using the T30 screwdriver and rotating counterclockwise until removed. If the screw is broken, use the extraction **Punch** or **Trephine** to remove the screw fragments.

Thread the Backslap Shaft into the extraction bolt and impact upward with the slotted mallet until the nail is removed.

### Removing Broken Nails

If the nail is broken, remove the proximal nail fragment lag screw and distal locking screws, as described above.

Once removed, insert the Ball-Tip Guidewire, 3.0x1000mm through the nail until the ball end protrudes past the distal nail fragment. Insert the **Nail Removal Wire** next to the ball-tip guidewire until it also protrudes past the nail fragment.

Attach the T-Handle 3 Jaw Chuck to the guidewire and tighten. Thread the long impaction rod in the back of the T-handle chuck. Using the Slotted Mallet, impact the impaction rod until the nail is removed.

# INSTRUMENT OVERVIEW

## PROXIMAL ENTRY



3.2mm Guidewire, Threaded Drill Point, 400mm, 6257.0021\*



3.2mm Guidewire, Drill Point, 400mm, 6257.0022\*



3.2mm Guidewire, Threaded Drill Point, 285mm, 6257.0031\*



3.2mm Guidewire, Drill Point, 285mm, 6257.0032\*



16mm Conical Opening Drill Bit, 6176.1008



16mm Coring Opening Drill Bit, 6176.1035\*



Awl, Curved, 6257.1053

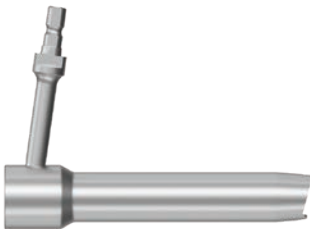

Protection Sleeve, 16mm, 6176.1009

## PROXIMAL ENTRY (CONT'D)



Hall Quick-Connect Handle, 6190.3000



Multi-Hole Wire Guide, 16mm, 6176.1018

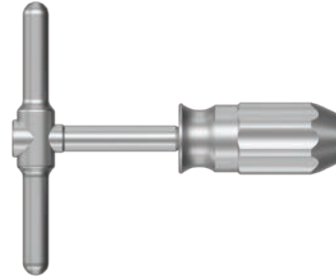

T-Handle 3 Jaw Chuck, 6173.9000



Ball-Tip Guidewire, 3.0x1000mm, 6176.0022S



Intramedullary Reduction Tool, Hall Connection, 6257.1062

## NAIL MEASUREMENT



Nail Length Gauge, 6176.0010



Extension, Nail Length Gauge, 6176.0011

## REAMING



Flexible Reamer Shaft, 470mm, Hall Connection, 6182.0004\*



Flexible Reamer Shaft, 620mm, Hall Connection, 6182.0005\*



Guidewire Pusher, 6176.0029



Front Cutting Reamer Head,  
8.5-9.5mm, 6182.2085-.2095



Front and Side Cutting Reamer Head,  
10-16mm, 6182.4100-.4160

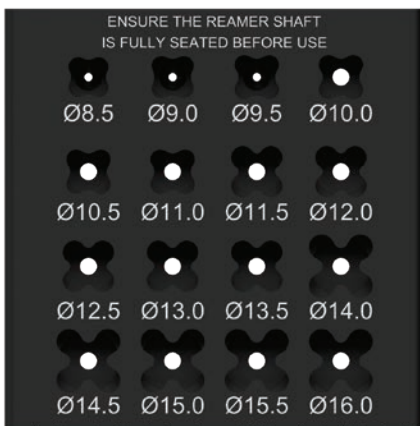

Universal Reamer Caddy, 9182.1001

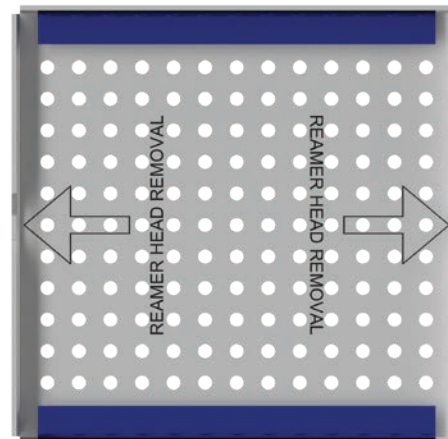

Universal Reamer Removal Tray, 9182.1002

## NAIL INSERTION



AUTOBAHN™ Trochanteric Nail,  
Insertion Handle, 6176.1021



Nail Connection Bolt, 6176.1000



Nail Connection Bolt Driver, Shaft, 6257.1044



Impaction Rod, Antegrade, 6257.1046

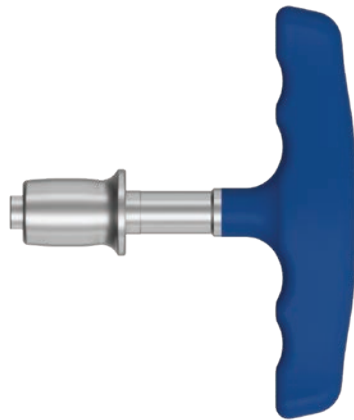

T-Handle Large, Hall QC, Fixed 6257.1058



Slotted Mallet, 6176.0020

## LAG SCREW INSERTION



AUTOBAHN™ Trochanteric Nail Aiming Arm, 125°, 6176.1022



AUTOBAHN™ Trochanteric Nail Aiming Arm, 130°, 6176.1023



Anti-Rotation Wire Sleeve, 6176.1019

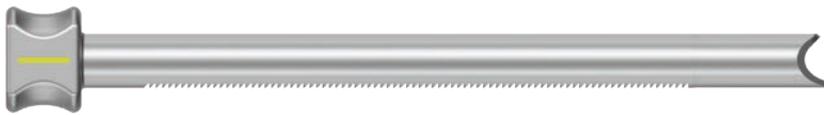

Driver Sleeve, Lag Screw, 6176.1001



Wire Sleeve, Lag Screw, 6176.1030



Trocar, Lag Screw, 6176.1003



Lag Screw Stepped Drill Bit, 10mm, 6176.1004



Hip Fastener Stepped Drill Bit, 10mm 6176.2004

## LAG SCREW INSERTION (CONT'D)



Drill Stop, Lag Screw, 6176.0007



Lag Screw Tap, 6176.1036



Lag Screw Driver, 6176.1005



Retention Rod, Lag Screw Driver, 6176.1012



Compressor, 6176.0035



T40 Set Screw Driver, Hinged, 6176.1013

## DISTAL LOCKING INSERTION (TARGETED)



Driver Sleeve, 5mm, 6257.1029



Drill Sleeve, 4.2mm, 6257.1030



Trocar, 4.2mm, 6257.1031



4.2mm Calibrated Drill Bit, 330mm, Short Flutes, 6257.2036\*



Depth Gauge, 5mm, Long, 6257.1050



T30 5mm Screwdriver for Power, Long, 6257.1080



Retention Rod, T30 5mm Screwdriver for Power, Long, 6257.1081

## DISTAL LOCKING INSERTION (FREEHAND)



4.2mm Drill Bit, 170mm, Short Flutes, 6257.2037\*



Direct Read Depth Gauge, 5mm, 6257.1038



Depth Gauge, 5mm, Short, 6257.1060



T30 Screwdriver for Power, Short, 6257.1063



Retention Rod, T30 Screwdriver for Power, Short, 6257.1064

*\*Available non-sterile or sterile.  
Add "S" to the end of the part number to indicate sterile.*

## DISTAL TARGETING



Distal Aiming Arm, 6176.1024

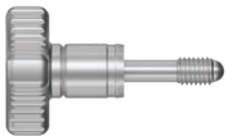

Distal Targeter Connection Screw, 6176.1032

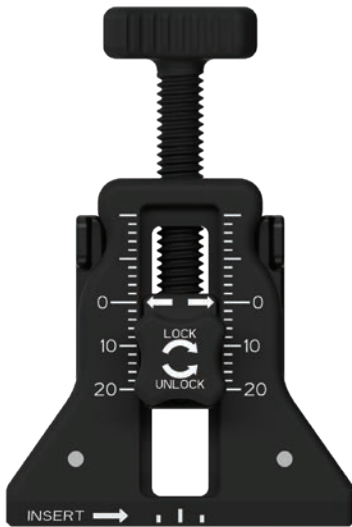

Deflection Device, Distal Targeter, 6176.1025



Troch Targeting Module, 6176.1026



Distal Targeting Alignment Shaft, 6176.1039

## REMOVAL



Extractor Pin Wrench, 6176.0066



Nail Extraction Bolt, 6176.0034



Backslap Shaft, 6257.1069

---

Nail Removal Wire, 6176.0030\*



Locking Screw Removal Tool, 6176.0031



Punch, 6176.0032



Trepine, 6176.0048

*\*Available non-sterile or sterile.  
Add "S" to the end of the part number to indicate sterile.*

# AUTOBAHN™ Trochanteric Nail Implants

## Nails (Sterile)

		125°	130°
9mm	Short (L/R)	1176.3917S	1176.5917S
	Left	1176.3930S-1176.3940S	1176.5930S-1176.5940S
	Right	1176.4930S-1176.4940S	1176.6930S-1176.6940S
10mm	Short (L/R)	1176.3017S	1176.5017S
	Left	1176.3032S-1176.3044S, 1176.9201S	1176.5032S-1176.5044S, 1176.9301S
	Right	1176.4032S-1176.4044S, 1176.9202S	1176.6032S-1176.6044S, 1176.9302S
11mm	Short (L/R)	1176.3117S	1176.5117S
	Left	1176.3132S-1176.3144S, 1176.9211S	1176.5132S-1176.5144S, 1176.9311S
	Right	1176.4132S-1176.4144S, 1176.9212S	1176.6132S-1176.6144S, 1176.9312S
12mm	Short (L/R)	1176.3217S	1176.5217S
	Left	1176.3232S-1176.3244S, 1176.9221S	1176.5232S-1176.5244S, 1176.9321S
	Right	1176.4232S-1176.4244S, 1176.9222S	1176.6232S-1176.6244S, 1176.9322S

## 10.5mm Lag Screws

Part No.	Length
1176.0070-1176.0130	70-130mm
1176.0070S-1176.0130S (Sterile)	70-130mm

## 10.5mm Hip Fasteners

Part No.	Length
1176.0170S-1176.0230S (Sterile)	70-130mm

## 5mm Locking Screws

Part No.	Length
1257.8320-1257.8400	20-100mm
1257.8320S-1257.8400S (Sterile)	20-100mm

## End Caps

Part No.	Length
1176.9000-1176.9020	0-20mm
1176.9000S-1176.9020S (Sterile)	0-20mm

## Guidewires

Part No.	Description
6257.0021	3.2mm Guidewire, Threaded Drill Point, 400mm
6257.0022	3.2mm Guidewire, Drill Point, 400mm
6257.0031	3.2mm Guidewire, Threaded Drill Point, 285mm
6257.0032	3.2mm Guidewire, Drill Point, 285mm
6176.0022S (Sterile)	Ball-Tip Guidewire, 3.0x1000mm

# AUTOBAHN™ EVO Universal Nailing Instrument Set 9176.9201

Part No.	Description	Qty
6173.9000	T-Handle 3 Jaw Chuck	1
6176.0010	Nail Length Gauge	1
6176.0011	Extension, Nail Length Gauge	1
6176.0020	Slotted Mallet	1
6176.0022S	Ball-Tip Guidewire, 3.0x1000mm	4
6176.0029	Guidewire Pusher	1
6176.0030	Nail Removal Wire	0
6176.0031	Locking Screw Removal Tool	0
6176.0032	Punch	0
6176.0048	Trephine	0
6176.0066	Extractor Pin Wrench	1
6182.0004	Flexible Reamer Shaft, 470mm, Hall Connection	2
6182.2085-6182.2095	Front Cutting Reamer Head, 8.5-9.5mm	1
6182.4100-6182.4160	Front and Side Cutting Reamer Head, 10-16mm	1
6183.1098	Ball Spike Pusher	1
6190.3000	Hall Quick-Connect Handle	1
6257.0021	3.2mm Guidewire, Threaded Drill Point, 400mm	4
6257.0022	3.2mm Guidewire, Drill Point, 400mm	4
6257.0031	3.2mm Guidewire, Threaded Drill Point, 285mm	4
6257.0032	3.2mm Guidewire, Drill Point, 285mm	4
6257.1029	Driver Sleeve, 5mm	1
6257.1030	Drill Sleeve, 4.2mm	1
6257.1031	Trocar, 4.2mm	1
6257.1038	Direct Read Depth Gauge, 5mm	1
6257.1044	Nail Connection Bolt Driver, Shaft	1
6257.1046	Impaction Rod, Antegrade	1
6257.1050	Depth Gauge, 5mm, Long	1
6257.1051	Countersink, 5mm Headless Locking Screws	1
6257.1053	Awl, Curved	1
6257.1058	T-Handle Large, Hall QC, Fixed	1
6257.1060	Depth Gauge, 5mm, Short	1
6257.1062	Intramedullary Reduction Tool, Hall Connection	1
6257.1063	T30 Screwdriver for Power, Short	1
6257.1064	Retention Rod, T30 Screwdriver for Power, Short	1
6257.1080	T30 5mm Screwdriver for Power, Long	2
6257.1081	Retention Rod, T30 5mm Screwdriver for Power, Long	1
6257.2036	4.2mm Calibrated Drill Bit, 330mm, Short Flutes	4
6257.2037	4.2mm Drill Bit, 170mm, Short Flutes	4
9182.1001	Universal Reamer Caddy	1
9182.1002	Universal Reamer Removal Tray	1
9176.1001	AUTOBAHN™ EVO Universal Instrument Set, Graphic Case	

# AUTOBAHN™ Trochanteric Nailing System PRO

## Instrument Set 9176.9202

Part No.	Description	Qty
1176.0070	AUTOBAHN™ Ti Lag Screw, 10.5x70mm	1
1176.0075	AUTOBAHN™ Ti Lag Screw, 10.5x75mm	1
1176.0080	AUTOBAHN™ Ti Lag Screw, 10.5x80mm	1
1176.0085	AUTOBAHN™ Ti Lag Screw, 10.5x85mm	2
1176.0090	AUTOBAHN™ Ti Lag Screw, 10.5x90mm	2
1176.0095	AUTOBAHN™ Ti Lag Screw, 10.5x95mm	2
1176.0100	AUTOBAHN™ Ti Lag Screw, 10.5x100mm	2
1176.0105	AUTOBAHN™ Ti Lag Screw, 10.5x105mm	2
1176.0110	AUTOBAHN™ Ti Lag Screw, 10.5x110mm	1
1176.0115	AUTOBAHN™ Ti Lag Screw, 10.5x115mm	1
1176.0120	AUTOBAHN™ Ti Lag Screw, 10.5x120mm	1
1176.0125	AUTOBAHN™ Ti Lag Screw, 10.5x125mm	1
1176.0130	AUTOBAHN™ Ti Lag Screw, 10.5x130mm	1
6176.0007	Drill Stop, Lag Screw	1
6176.0034	Nail Extraction Bolt	1
6176.0035	Compressor	1
6176.1000	Nail Connection Bolt	2
6176.1001	Driver Sleeve, Lag Screw	1
6176.1003	Trocar, Lag Screw	1
6176.1004	Lag Screw Stepped Drill Bit, 10mm	1
6176.1005	Lag Screw Driver	1
6176.1008	16mm Conical Opening Drill Bit	1
6176.1009	Protection Sleeve, 16mm	1
6176.1012	Retention Rod, Lag Screw Driver	1
6176.1013	T40 Set Screw Driver, Hinged	1
6176.1018	Multi-Hole Wire Guide, 16mm	1
6176.1019	Anti-Rotation Wire Sleeve	2
6176.1021	AUTOBAHN™ Trochanteric Nail, Insertion Handle	1
6176.1022	AUTOBAHN™ Trochanteric Nail Aiming Arm, 125°	1
6176.1023	AUTOBAHN™ Trochanteric Nail Aiming Arm, 130°	1
6176.1030	Wire Sleeve, Lag Screw	1
6176.1035	16mm Coring Opening Drill Bit	0
6176.1036	Lag Screw Tap	1
6176.2004	Hip Fastener Stepped Drill Bit, 10mm	0
6257.1069	Backslap Shaft	1
9176.1002	AUTOBAHN™ Trochanteric Nail PRO Instrumentation Set, Graphic Case	

# AUTOBAHN™ EVO Universal

## Screw Set 9176.9203

Part No.	Description	Qty
1257.8320	AUTOBAHN™ EVO Locking Screw, 5x20mm, Ti	2
1257.8323	AUTOBAHN™ EVO Locking Screw, 5x22.5mm, Ti	2
1257.8325	AUTOBAHN™ EVO Locking Screw, 5x25mm, Ti	3
1257.8328	AUTOBAHN™ EVO Locking Screw, 5x27.5mm, Ti	3
1257.8330	AUTOBAHN™ EVO Locking Screw, 5x30mm, Ti	3
1257.8333	AUTOBAHN™ EVO Locking Screw, 5x32.5mm, Ti	3
1257.8335	AUTOBAHN™ EVO Locking Screw, 5x35mm, Ti	3
1257.8338	AUTOBAHN™ EVO Locking Screw, 5x37.5mm, Ti	3
1257.8340	AUTOBAHN™ EVO Locking Screw, 5x40mm, Ti	3
1257.8343	AUTOBAHN™ EVO Locking Screw, 5x42.5mm, Ti	3
1257.8345	AUTOBAHN™ EVO Locking Screw, 5x45mm, Ti	3
1257.8348	AUTOBAHN™ EVO Locking Screw, 5x47.5mm, Ti	3
1257.8350	AUTOBAHN™ EVO Locking Screw, 5x50mm, Ti	3
1257.8353	AUTOBAHN™ EVO Locking Screw, 5x52.5mm, Ti	3
1257.8355	AUTOBAHN™ EVO Locking Screw, 5x55mm, Ti	3
1257.8358	AUTOBAHN™ EVO Locking Screw, 5x57.5mm, Ti	3
1257.8360	AUTOBAHN™ EVO Locking Screw, 5x60mm, Ti	3
1257.8365	AUTOBAHN™ EVO Locking Screw, 5x65mm, Ti	3
1257.8370	AUTOBAHN™ EVO Locking Screw, 5x70mm, Ti	3
1257.8375	AUTOBAHN™ EVO Locking Screw, 5x75mm, Ti	3
1257.8380	AUTOBAHN™ EVO Locking Screw, 5x80mm, Ti	3
1257.8385	AUTOBAHN™ EVO Locking Screw, 5x85mm, Ti	3
1257.8390	AUTOBAHN™ EVO Locking Screw, 5x90mm, Ti	3
1257.8395	AUTOBAHN™ EVO Locking Screw, 5x95mm, Ti	3
1257.8400	AUTOBAHN™ EVO Locking Screw, 5x100mm, Ti	3
1257.8520	AUTOBAHN™ EVO Headless Locking Screw, 5x20mm, Ti	2
1257.8523	AUTOBAHN™ EVO Headless Locking Screw, 5x22.5mm, Ti	2
1257.8525	AUTOBAHN™ EVO Headless Locking Screw, 5x25mm, Ti	3
1257.8528	AUTOBAHN™ EVO Headless Locking Screw, 5x27.5mm, Ti	3
1257.8530	AUTOBAHN™ EVO Headless Locking Screw, 5x30mm, Ti	3
1257.8533	AUTOBAHN™ EVO Headless Locking Screw, 5x32.5mm, Ti	3
1257.8535	AUTOBAHN™ EVO Headless Locking Screw, 5x35mm, Ti	3
1257.8538	AUTOBAHN™ EVO Headless Locking Screw, 5x37.5mm, Ti	3
1257.8540	AUTOBAHN™ EVO Headless Locking Screw, 5x40mm, Ti	3
1257.8543	AUTOBAHN™ EVO Headless Locking Screw, 5x42.5mm, Ti	3

# AUTOBAHN™ EVO Universal

## Screw Set 9176.9203 (Cont'd)

<b>Part No.</b>	<b>Description</b>	<b>Qty</b>
1257.8545	AUTOBAHN™ EVO Headless Locking Screw, 5x45mm, Ti	3
1257.8548	AUTOBAHN™ EVO Headless Locking Screw, 5x47.5mm, Ti	3
1257.8550	AUTOBAHN™ EVO Headless Locking Screw, 5x50mm, Ti	3
1257.8553	AUTOBAHN™ EVO Headless Locking Screw, 5x52.5mm, Ti	3
1257.8555	AUTOBAHN™ EVO Headless Locking Screw, 5x55mm, Ti	3
1257.8558	AUTOBAHN™ EVO Headless Locking Screw, 5x57.5mm, Ti	3
1257.8560	AUTOBAHN™ EVO Headless Locking Screw, 5x60mm, Ti	3
1257.8565	AUTOBAHN™ EVO Headless Locking Screw, 5x65mm, Ti	3
1257.8570	AUTOBAHN™ EVO Headless Locking Screw, 5x70mm, Ti	3
1257.8575	AUTOBAHN™ EVO Headless Locking Screw, 5x75mm, Ti	3
1257.8580	AUTOBAHN™ EVO Headless Locking Screw, 5x80mm, Ti	3
1257.8585	AUTOBAHN™ EVO Headless Locking Screw, 5x85mm, Ti	3
1257.8590	AUTOBAHN™ EVO Headless Locking Screw, 5x90mm, Ti	3
1257.8595	AUTOBAHN™ EVO Headless Locking Screw, 5x95mm, Ti	3
1257.8600	AUTOBAHN™ EVO Headless Locking Screw, 5x100mm, Ti	3
9176.1003	AUTOBAHN™ EVO Universal Screw Set, Graphic Case	

# AUTOBAHN™ Distal Targeting

## Instrument Set 9176.9205

<b>Part No.</b>	<b>Description</b>	<b>Qty</b>
6176.1024	Distal Aiming Arm	1
6176.1025	Deflection Device, Distal Targeter	1
6176.1026	Troch Targeting Module	1
6176.1027	EVO GT Targeting Module	1
6176.1028	EVO PF Left Targeting Module	1
6176.1029	EVO PF Right Targeting Module	1
6176.1032	Distal Targeter Connection Screw	1
6176.1039	Distal Targeter Alignment Shaft	1
9176.1005	AUTOBAHN™ Distal Targeting, Graphic Case	

# AUTOBAHN™ Hip Fastener Implant Set 9176.9301

<b>Part No.</b>	<b>Description</b>	<b>Qty</b>
1176.0170S	AUTOBAHN™ Ti Hip Fastener, 10.5x70mm	2
1176.0175S	AUTOBAHN™ Ti Hip Fastener, 10.5x75mm	2
1176.0180S	AUTOBAHN™ Ti Hip Fastener, 10.5x80mm	2
1176.0185S	AUTOBAHN™ Ti Hip Fastener, 10.5x85mm	2
1176.0190S	AUTOBAHN™ Ti Hip Fastener, 10.5x90mm	2
1176.0195S	AUTOBAHN™ Ti Hip Fastener, 10.5x95mm	2
1176.0200S	AUTOBAHN™ Ti Hip Fastener, 10.5x100mm	2
1176.0205S	AUTOBAHN™ Ti Hip Fastener, 10.5x105mm	2
1176.0210S	AUTOBAHN™ Ti Hip Fastener, 10.5x110mm	2
1176.0215S	AUTOBAHN™ Ti Hip Fastener, 10.5x115mm	2
1176.0220S	AUTOBAHN™ Ti Hip Fastener, 10.5x120mm	2
1176.0225S	AUTOBAHN™ Ti Hip Fastener, 10.5x125mm	2
1176.0230S	AUTOBAHN™ Ti Hip Fastener, 10.5x130mm	2
9176.3001	AUTOBAHN™ Hip Fastener, Soft Case	

# Important Information on the AUTOBAHN™ Nailing System

For symbols glossary, please refer to [www.globusmedical.com/eIFU](http://www.globusmedical.com/eIFU)

## WITHIN THE UNITED STATES ONLY

### DESCRIPTION

The AUTOBAHN™ Nailing System is a family of intramedullary nails, screws, and washers designed to be used for internal bone fixation. The implants are available in various lengths and diameters to accommodate a wide range of patient anatomy. The nails are secured with locking screws. AUTOBAHN™ Hip Fastener with Helical Hook Technology is used with AUTOBAHN™ Trochanteric Nails. All devices are manufactured from titanium alloy, stainless steel, cobalt chromium molybdenum alloy, or titanium molybdenum alloy, and may include radiolucent PEEK polymer inserts.

### INDICATIONS

The AUTOBAHN™ Tibial Nail is indicated for stabilization of fractures in skeletally mature patients, specifically fractures of the proximal and distal tibia and the tibial shaft, open and closed tibial shaft fractures, certain pre- and postisthmic fractures, non-unions, malunions, pseudoarthrosis, corrective osteotomies, prophylactic nailing of impending pathological fractures, tumor resections, simple long bone fractures, severely comminuted, spiral, large oblique and segmental fractures, polytrauma and multiple fractures, reconstruction, following tumor resection and grafting, supracondylar fractures, and bone lengthening and shortening.

The AUTOBAHN™ Trochanteric Nail is indicated for treatment of fractures in adults and adolescents (12-21 years of age) in which the growth plates have fused for the following indications: basal neck fractures, fixation of stable and unstable intertrochanteric, pertrochanteric, and subtrochanteric fractures (including osteoporotic and osteopenic bone), pathologic fractures (including prophylactic use) in both trochanteric and diaphyseal regions, combinations of pertrochanteric, intertrochanteric, basal neck fractures, long subtrochanteric fractures, tumor resections, fractures resulting from trauma, nonunions, malunions, and revision procedures.

AUTOBAHN™ Antegrade/Retrograde Femoral Nails are indicated for long bone fracture fixation in skeletally mature patients, specifically femoral fracture fixation, which may include the following: open and closed femoral fractures, pseudoarthrosis and correction osteotomy, pathologic fractures, impending pathologic fractures, tumor resections, supracondylar fractures, including those with intra-articular extension, ipsilateral hip/shaft fractures, ipsilateral femur/tibia fractures, fractures proximal to a total knee arthroplasty, fractures distal to hip joint, nonunions and malunions, poly trauma patients, fractures in the morbidly obese, fractures involving osteopenic and osteoporotic bone, compound and simple shaft fractures, proximal, metaphyseal, and distal shaft fractures, segmental fractures, closed supracondylar fractures, fractures involving femoral condyles, comminuted fractures, fractures with bone loss, and periprosthetic fractures.

AUTOBAHN™ EVO Femoral Nails are indicated for long bone fracture fixation in skeletally mature patients, specifically femoral fracture fixation, which may include the following: open and closed femoral fractures, pseudoarthrosis and correction osteotomy, pathologic fractures, impending pathologic fractures, tumor resections, supracondylar fractures, including those with intra-articular extension, ipsilateral hip/shaft fractures, ipsilateral femur/tibia fractures, fractures proximal to a total knee arthroplasty, fractures distal to hip joint, nonunions and malunions, poly trauma patients, fractures in the morbidly obese, fractures involving osteopenic and osteoporotic bone, compound and simple shaft fractures, proximal, metaphyseal, and distal shaft fractures, segmental fractures, closed supracondylar fractures, fractures involving femoral condyles, comminuted fractures, fractures with bone loss, and periprosthetic fractures. In addition, the AUTOBAHN™ EVO Antegrade Nails are intended for use in adolescents (12-21 years) in which the growth plates have fused.

### CONTRAINDICATIONS

Use of these implants is contraindicated in patients with the following conditions:

- Any active or suspended latent infection or marked local inflammation, or when the patient has demonstrated allergy or foreign body sensitivity to any of the implant materials.
- Compromised vascularity that would inhibit adequate blood supply to the fracture or the operative site.
- Bone stock compromised by disease, infection or prior implantation that cannot provide adequate support and/or fixation of the devices.
- A medullary canal obliterated by a previous fracture or tumor.
- Skeletally immature patients.
- Material sensitivity, documented or suspected.
- Patients having inadequate tissue coverage over the operative site.
- Any mental or neuromuscular disorder which would create an unacceptable risk of fixation failure or complications in postoperative care.
- Other medical or surgical conditions which would preclude the potential benefit of surgery.

### WARNINGS

The correct implant selection is extremely important. Failure to use the appropriate implant for the fracture condition may accelerate clinical failure. Failure to use the proper component to maintain adequate blood supply and provide

rigid fixation may result in loosening, bending, cracking or fracture of the implant and/or bone. The correct implant size for a given patient can be determined by evaluating the patient's height, weight, functional demands and anatomy. Every implant must be used in the correct anatomic location, consistent with accepted standards of internal fixation.

### PRECAUTIONS

The implantation of intramedullary nail devices should be performed only by experienced surgeons with specific training in the use of this system because this is a technically demanding procedure presenting a risk of serious injury to the patient. Preoperative planning and patient anatomy should be considered when selecting implant size.

Surgical implants must never be reused. An explanted implant must never be reimplanted. Even though the device appears undamaged, it may have small defects and internal stress patterns which could lead to breakage.

### MRI SAFETY INFORMATION

These devices have not been evaluated for safety in the MR environment. It has not been tested for heating or unwanted movement in the MR environment. The safety of these devices in the MR environment is unknown. Performing an MR exam on a person who has this medical device may result in injury or device malfunction.

### CAUTIONS

#### Pre-operative

- Implants are single use only.
- Implants that came in contact with body fluids should never be reused.
- Ensure that all components needed for surgery are available in the surgical suite.
- Inspection is recommended prior to surgery to determine if implants have been damaged during storage.
- While rare, intra-operative fracture or breakage of instruments can occur. Instruments which have experienced excessive use or excessive force are susceptible to fracture. Instruments should be examined for wear or damage prior to surgery.

#### Intra-operative

- Avoid surface damage of implants.
- Discard all damaged or mishandled implants
- Contouring or bending of an implant should be avoided where possible, because it may reduce its fatigue strength and can cause failure under load.
- Implants are available in different versions, varying for example in length, diameter, material and number of drilled holes. Select the required version carefully.
- During the course of the operation, repeatedly check to ensure that the connection between the implant and the instrument, or between the instruments, is secure.
- Implants which consist of several components must only be used in the prescribed combination (refer to the AUTOBAHN™ Surgical Technique Guide).
- After the procedure check the proper positioning of all implants using fluoroscopy.
- Do not use components from this system in conjunction with components from any other manufacturer's system unless otherwise specified (refer to the AUTOBAHN™ Surgical Technique Guide).

#### Post-operative

- Post-operative patient activity: These implants are neither intended to carry the full load of the patient acutely, nor intended to carry a significant portion of the load for extended periods of time. For this reason post-operative instructions and warnings to patients are extremely important. External immobilization (e.g. bracing or casting) may be employed until X-rays or other procedures confirm adequate bone consolidation.
- The injured limb should be kept elevated.
- For stable fracture that are locked statically or dynamically, full weight bearing walking may be started immediately.
- In the event of a delay in bone consolidation, or if such consolidation does not take place, or if explantation is not carried out, complications may occur, for example fracture or loosening of the implant or instability of the implant system.

# Important Information on the AUTOBAHN™ Nailing System

Regular post-operative examinations (e.g., X-ray checks) are advisable.

- If patients cannot follow the recommendations of the physician because of any mental or neuromuscular disorder. For this reason those patients must have additional post-operative follow-up.
- Implant removal should be followed by adequate postoperative management to avoid fracture or refracture of the bone.

## Informing the Patient

The implant affects the patient's ability to carry loads and her/his mobility and general living circumstances. The surgeon must counsel each patient individually on correct behavior and activity after the implantation.

The surgeon must warn patient that the device cannot and does not replicate a normally healthy bone, that the device can break or become damaged as a result of strenuous activity, trauma, malunion or non-union and that the device has a finite expected service life and may need to be removed at some time in the future.

## ADVERSE EFFECTS

In many instances, adverse results may be clinically related rather than device related. The following are the most frequent adverse effects involving the use of internal fracture fixation devices:

- Delayed union or non-union of the fracture site.
- These devices can break when subjected to the increased loading associated with delayed unions and/or non-unions. Internal fixation devices are load sharing devices which are intended to hold fracture bone surface in a position to facilitate healing. If healing is delayed or does not occur, the appliance may eventually break due to metal fatigue. Loads on the device produced by load bearing and the patient's activity level will dictate the longevity of the device.
- Conditions attributable to non-union, osteoporosis, osteomalacia, diabetes, inhibited revascularization and poor bone formation can cause loosening, bending, cracking, fracture of the device or premature loss of rigid fixation with the bone.
- Improper alignment can cause a malunion of the bone and/or bending, cracking or even breakage of the device.
- Increased fibrous tissue response around the fracture site due to unstable comminuted fractures.
- Early or late infection, deep or superficial.
- Deep venous thrombosis.
- Avascular necrosis.
- Shortening of the effected bone/fracture site.
- Subclinical nerve damage may possibly occur as a result of the surgical trauma.
- Material sensitivity reactions in patients following surgical implantation have rarely been reported, however their significance awaits further clinical evaluation.
- Fat embolism or adult respiratory distress from reaming the medullary canal.

## PACKAGING

These implants and instruments may be supplied pre-packaged and sterile, using gamma irradiation. The integrity of the sterile packaging should be checked to ensure that sterility of the contents is not compromised. Packaging should be carefully checked for completeness and all components should be carefully checked to ensure that there is no damage prior to use. Damaged packages or products should not be used, and should be returned to Globus Medical. During surgery, after the correct size has been determined, remove the products from the packaging using aseptic technique.

These implants and instruments may also be provided nonsterile and are steam sterilized prior to use, as described in the STERILIZATION section below. Following use or exposure to soil, instruments and instrument trays and cases must be cleaned, as described in the CLEANING section below.

## HANDLING

All instruments and implants should be treated with care. Improper use or handling may lead to damage and/or possible malfunction. Instruments should be checked to ensure that they are in working order prior to surgery.

Implants and sterile-packed instruments are single use devices and should not be cleaned. Re-cleaning of single use implants might lead to mechanical failure and/or material degradation. Discard any implants that may have been accidentally contaminated.

## CLEANING

Instruments should be cleaned separately from instrument trays and cases. Lids should be removed from cases for the cleaning process, if applicable. All instruments that can be disassembled must be disassembled for cleaning.

All handles must be detached. Instruments may be reassembled following sterilization. The products should be cleaned using neutral cleaners before sterilization and introduction into a sterile surgical field or (if applicable) return of the product to Globus Medical.

Cleaning and disinfecting can be performed with aldehyde-free solvents at higher temperatures. Cleaning and decontamination must include the use of neutral cleaners followed by a deionized water rinse. Note: certain cleaning solutions such as those containing formalin, glutaraldehyde, bleach and/or other alkaline cleaners may damage some devices, particularly instruments; these solutions should not be used.

The following cleaning methods should be observed when cleaning instruments and instrument trays and cases after use or exposure to soil, and prior to sterilization:

1. Immediately following use, ensure that the instruments are wiped down to remove all visible soil and kept from drying by submerging or covering with a wet towel.
2. Disassemble all instruments that can be disassembled.
3. Rinse the instruments under running tap water to remove all visible soil. Flush the lumens a minimum of 3 times, until the lumens flush clean.
4. Prepare Enzol® (or a similar enzymatic detergent) per manufacturer's recommendations.
5. Immerse the instruments in the detergent and allow them to soak for a minimum of 2 minutes.
6. Use a soft bristled brush to thoroughly clean the instruments. Use a pipe cleaner for any lumens. Pay close attention to hard to reach areas.
7. Using a sterile syringe, draw up the enzymatic detergent solution. Flush any lumens and hard to reach areas until no soil is seen exiting the area.
8. Remove the instruments from the detergent and rinse them in running warm tap water.
9. Prepare Enzol® (or a similar enzymatic detergent) per manufacturer's recommendations in an ultrasonic cleaner.
10. Completely immerse the instruments in the ultrasonic cleaner and ensure detergent is in lumens by flushing the lumens. Sonicate for a minimum of 3 minutes.
11. Remove the instruments from the detergent and rinse them in running deionized water or reverse osmosis water for a minimum of 2 minutes.
12. Dry instruments using a clean soft cloth and filtered pressurized air.
13. Visually inspect each instrument for visible soil. If visible soil is present, then repeat cleaning process starting with Step 3.

## CONTACT INFORMATION

Globus Medical may be contacted at 1-866-GLOBUS1 (456-2871). A surgical technique manual may be obtained by contacting Globus Medical.

## STERILIZATION

These implants and instruments may be available sterile or nonsterile.

Sterile implants are sterilized by gamma radiation, validated to ensure a Sterility Assurance Level (SAL) of 10<sup>-6</sup>. Sterile products are packaged in a heat sealed Tyvek tray, container/pouch, or pouch/pouch; or thermoplastic polyurethane (TPU) pouch inside a poly/Tyvek pouch; or, vacuum sealed Nylon pouch/pouch. The expiration date is provided in the package label. These products are considered sterile unless the packaging has been opened or damaged. Sterile implants meet pyrogen limit specifications.

Nonsterile implants and instruments have been validated following ISO 17665-1:2006 Sterilization of health care products – Moist heat to ensure an SAL of 10<sup>-6</sup>. The use of an FDA-cleared wrap is recommended, per the Association for the Advancement of Medical Instrumentation (AAMI) ST79, *Comprehensive Guide to Steam Sterilization and Sterility Assurance in Health Care Facilities*. It is the end user's responsibility to use only sterilizers and accessories (such as sterilization wraps, sterilization pouches, chemical indicators, biological indicators, and sterilization cassettes) that have been cleared by the FDA for the selected sterilization cycle specifications (time and temperature).

When using a rigid sterilization container, the following must be taken into consideration for proper sterilization of Globus devices and loaded graphic cases:

- Recommended sterilization parameters are listed in the table below.
- Only FDA-cleared rigid sterilization containers for use with pre-vacuum steam sterilization may be used.
- When selecting a rigid sterilization container, it must have a minimum filter area of 176 in<sup>2</sup> total, or a minimum of four(4) 7.5in diameter filters.

## Important Information on the AUTOBAHN™ Nailing System

- No more than one (1) loaded graphic case or its contents can be placed directly into a rigid sterilization container.
- Stand-alone modules/racks or single devices must be placed, without stacking, in a container basket to ensure optimal ventilation.
- The rigid sterilization container manufacturer's instructions for use are to be followed; if questions arise, contact the manufacturer of the specific container for guidance.
- Refer to AAMI ST79 for additional information concerning the use of rigid sterilization containers.

For implants and instruments provided NONSTERILE, sterilization is recommended (wrapped or containerized) as follows:

Method	Cycle Type	Temperature	Exposure Time	Drying Time
Steam	Pre-vacuum	132°C (270°F)	4 Minutes	30 Minutes

*These parameters are validated to sterilize only this device. If other products are added to the sterilizer, the recommended parameters are not valid and new cycle parameters must be established by the user. The sterilizer must be properly installed, maintained, and calibrated. Ongoing testing must be performed to confirm inactivation of all forms of viable microorganisms.*

**CAUTION:** Federal (USA) Law Restricts this Device to Sale by or on the order of a Physician.

**DI203A Rev F**



Globus Medical  
Valley Forge Business Center  
2560 General Armistead Avenue  
Audubon, PA 19403  
[globusmedical.com](http://globusmedical.com)

Customer Service:

Phone 1-866-GLOBUS1 (or 1-866-456-2871)  
Fax 1-866-GLOBUS3 (or 1-866-456-2873)

©2026 Globus Medical. All rights reserved. Patent [www.globusmedical.com/patents](http://www.globusmedical.com/patents).  
Life moves us is a registered trademark of Globus Medical. Please refer to the applicable  
system instructions for use (IFU) for description, indications, contraindications, warnings,  
precautions and other important information at [globusmedical.com/eIFU](http://globusmedical.com/eIFU).

GMTGD288  
04.26 Rev B