

NuVasive Specialized Orthopedics

PRECICE Intramedullary Limb Lengthening System Instructions for Use

Product Description:

The **PRECICE Intramedullary Limb Lengthening (IMLL) System** is composed of an implantable intramedullary nail, locking screws, reusable instruments, and a hand-held External Remote Controller (ERC). The Precice Intramedullary Limb Lengthening System implants are manufactured from Titanium 6AL-4V per ASTM F136. The PRECICE Intramedullary Limb Lengthening nail is a sterile single use device that is surgically implanted using the instruments and locking screws for osteoplasty lengthening utilizing distraction osteogenesis. The ERC is used daily after implantation to non-invasively lengthen or shorten the implant to a prescribed length.

During the implantation procedure, the nail can be adjusted in length to provide an appropriate amount of compression for the proper fracture reduction. Following implantation, the PRECICE Intramedullary Limb Lengthening System utilizes distraction osteogenesis to lengthen the limb. Traditional intramedullary surgical techniques are used to implant and secure the proximal and distal sections of the PRECICE Intramedullary Limb Lengthening nail to the target bone. The PRECICE Intramedullary Limb Lengthening nail includes a small internal magnet and gearing. After positioning the External Remote Controller (ERC) against the skin over the internal magnet, activation of the ERC causes the magnet to rotate and either lengthen or shorten the nail.

During the surgical implantation procedure and after the nail has been secured to the bone, the nail can be shortened up to 10mm for femoral and tibial implants and up to 20 mm for humeral implants to provide compression for fracture reduction. Over a period of days, weeks, or months, sequential distractions are used to produce the target limb length or compensate for any length discrepancies encountered during the fracture reduction process. The PRECICE Intramedullary Limb Lengthening nail remains implanted until bone consolidation has been completed. Once the physician determines that the nail has achieved its intended use and is no longer required, it is removed using standard surgical techniques.

Intended Use:

The PRECICE Intramedullary Limb Lengthening System is intended for limb lengthening, open and closed fracture fixation, pseudoarthrosis, mal-unions, non-unions, or bone transport of long bones in adults.

Contraindications:

- Infection or Pathologic conditions of bone such as osteopenia which would impair the ability to securely fix the device.
- Patients with Gustilo open fracture Classification Grade IIIB or IIIC fractures
- Patients with pre-existing nerve palsies
- Metal allergies and sensitivities.
- Patients with an irregular bone diameter that would prevent insertion of the PRECICE Intramedullary Limb Lengthening nail.
- Patients in which the PRECICE Intramedullary Limb Lengthening nail would cross joint spaces or open epiphyseal growth plates.
- Patients in which there is an obliterated medullary canal or other conditions that tend to retard healing such as blood supply limitations, peripheral vascular disease or evidence of inadequate vascularity.
- Patients unwilling or incapable of following postoperative care instructions.

Please refer to the table below for contraindications with regard to weight and maximum distance of the treated limb to the surface of the intramedullary canal.

Limb	PRECICE IMLL Model	Nail Diameter		Maximum Distance of Treated Limb Surface to IM Canal (ERC1, ERC2P)	Maximum Distance of Treated Limb Surface to IM Canal (ERC3P)	Maximum Distance of Treated Limb to Surface of IM Canal (ERC4P)	Maximum Patient Weight	
Tibia	C	8.5 mm, 9.0 mm, 9.5 mm, 10.0 mm, 10.5 mm		13 mm	13 mm	13 mm	57 Kg	
		10.7 mm, 11.5 mm, 12.5 mm		13 mm	13 mm	16 mm	114 kg	
	J	8.5 mm		13 mm	13 mm	13 mm	57 Kg	
		10.7 mm, 12.5 mm		13 mm	13 mm	16 mm	114 kg	
	Q	8.5 mm		13 mm	13 mm	13 mm	57 Kg	
		10.7 mm		13 mm	13 mm	16 mm	57 Kg	
Femur	A-G (except C), V, X	8.5 mm, 9.0 mm, 9.5 mm, 10.0 mm, 10.5 mm		38 mm	38 mm	45 mm	57 kg	
		10.7 mm, 11.5 mm		51 mm	51 mm	75 mm	114 kg	
		12.5 mm		51 mm	80 mm	90 mm	114 kg	
	H, K, U	8.5 mm		38 mm	38 mm	45 mm	57 kg	
		10.7 mm		51 mm	51 mm	75 mm	114 kg	
		12.5 mm		51 mm	80 mm	90 mm	114 kg	
	N, M, P	8.5 mm		38 mm	38 mm	45 mm	57 kg	
		10.7 mm		51 mm	51 mm	75 mm	57 kg	
	Humerus	L, M	165 - 210 mm pre-distracted length	8.5 mm	25.4 mm	25.4 mm	25 mm	Non-weight bearing
			225 - 300 mm pre-distracted length		51 mm	51 mm	45 mm	Non-weight bearing

Potential Adverse Events and Complications:

As this is a major surgical procedure, there are known complications associated with orthopedic surgery such as bone fractures, nonunion, delayed union, malunion, premature healing (consolidation), decrease in bone density due to stress shielding, inadequate screw fixation, difficulty with nail or screw removal, early or late infection that may result in the need for additional surgeries, damage to blood vessels or nerves, deep venous thrombosis or pulmonary emboli, acute local inflammatory response, loss of sensory and/or motor function or paralysis, pain, and/or permanent deformity.

The following list of failures and adverse events are possible with the Precice IMLL system. Failure to follow the contraindications, warnings, cautions and precautions listed in this IFU constitute off-label use and may increase the likelihood of these events.

- Soft tissue contractures, loss of joint motion, subluxation and/or dislocation could result in pain or surgical intervention to resolve. Preventative measures should be considered such as but not limited to proactive examinations, change of prescription, bracing, physical therapy, and tissues releases
- Local tissue discoloration (i.e., metallosis), osteolysis, local acute inflammatory response, pain or other harms associated with exposure to wear debris, metal nanoparticles, and elevated titanium serum ion levels (including neurological issues and the risks associated with reproductive and developmental toxicity).

- Exposure to biohazards or non-biocompatible materials potentially leading to immunological response, pain, skin irritation/rash/sensitization, developmental toxicity related harms and/or infection and which may require medical intervention such as revision surgery.
- Loss of distraction or uncontrolled lengthening which may lead to pain, loss of correction, extension of treatment, progression of deformity, increased limb length discrepancy, over-lengthening, poor regenerate and/or necessitate revision surgery.
- Implant bending, fracture, loosening, disassociation and/or loss of fixation resulting in medical intervention such as revision surgery.
- Failure to lengthen which may lead to delays in surgery (leading to additional blood loss and extended exposure to anesthesia), extension of treatment, suboptimal correction, and/or necessitate revision or reoperation.
- Treatment complications from anatomical compatibility issues due to implant configuration selection, implant removals and/or implant sterility which may lead to delays in surgery (leading to additional blood loss and extended exposure to anesthesia), inability to complete the procedure and/or cancellation of the procedure, or may result in pain, abnormal sensations and/or suboptimal correction.

Warnings:

- The PRECICE Intramedullary Limb Lengthening nail cannot withstand the stresses of full weight bearing for tibia and femur applications. For humerus applications, patients should not bear any weight on the treated limb. Patients should utilize external support and/or restrict activities until consolidation occurs.
- Patients with an open fracture or prior external fixator treatment resulting in limb length discrepancy may also have soft tissue damage/dormant infections as a result of severe trauma. It is important that soft tissue damage is addressed prior to lengthening to minimize the risk of infection.
- Limb lengthening also involved soft tissues; it is important to allow the soft tissue to heal prior to the lengthening procedure and previous/current incision sites should be monitored.
- Do not use if the sterile packaging has been damaged or is open.
- Metallic implants can loosen, fracture, corrode, migrate, or cause pain.
- Due to the presence of a magnet, use of the PRECICE Intramedullary Limb Lengthening System is not recommended in patients with pacemakers.
- The PRECICE Intramedullary Limb Lengthening System may not be appropriate for patients with poly-trauma.
- Use of the PRECICE Intramedullary Limb Lengthening System in patients with an active infection of the treated bone is not recommended.
- Smoking, chronic steroid/drug use and the use of other anti-inflammatory drugs have been determined to affect bone healing and could potentially have an adverse effect of the bone regenerate during the lengthening process. Additionally, patients should be evaluated for narcotic dependencies associated with pain management.
- The PRECICE Intramedullary Limb Lengthening nail is supplied sterile and is for single use only. The nail has not been tested to be cleaned or sterilized for multiple uses. If the nail is used more than once, the device may not be sterile and could cause a serious infection.
- The Precice Screws may be provided sterile or non-sterile, take careful note to read packaging if screw is provided sterile or non-sterile.
- Before removing the implants from the package, make sure that the protective packaging is unopened and undamaged. If the packaging is damaged, the implants have to be considered as NON-STERILE and may not be used.
- Note the STERILE expiry date. Implants with elapsed STERILE expiry dates have to be considered as non-sterile.
- The PRECICE Intramedullary Limb Lengthening Nail should be retracted only by a physician. Retraction should be monitored and confirmed using radiography.

- To avoid dislocation or subluxation of the shoulder joint with the Humeral Nail, careful preoperative planning should be done to determine the correct lengthening prescription. The typical lengthening prescription for lengthening is 1 mm/day.
- Compression and distraction of the Humeral Nail should be performed postoperatively, while the patient is awake to monitor their neurovascular status and radial nerve.
- There is a possibility of nerve or soft tissue damage and/or weakness related to either surgical trauma or the presence of the implant, advise the patient to notify the surgeon of any experienced pain, numbness, or weakness while undergoing treatment.
- Patients will require assistance from another person when using the ERC to lengthen the humerus.
- Humeral nail distraction may cause traction on nerves.
- Patients of the PRECICE Intramedullary Limb Lengthening System should not be implanted with more than two devices at a time and the patients weight should be a minimum of 50 lbs. Failure to follow this criteria may result in the potential adverse events and complications described above.
- **MRI Information**: The PRECICE Intramedullary Limb Lengthening System is MR Unsafe. A patient with the implanted PRECICE Intramedullary Limb Lengthening nail must not come near an MRI scanner and must not undergo an MRI scan.

Precautions:

- Do not use this device without proper training in both device implantation and adjustment. Refer to External Remote Controller (ERC, ERC 2P, ERC 3P, or ERC 4P) Operator's Manual (OM0005, OM0009, OM0016, or OM0017) for operation of the External Remote Controller.
- During the distraction phase, patient should not participate in contact sports or other high-risk activities that cause more than 20% of body weight to be loaded on the treated limb. These activities may resume upon sufficient bone consolidation, but only as determined by the physician.
- Examine all PRECICE Intramedullary Limb Lengthening System components carefully prior to use to assure proper working condition. If you suspect a component to be faulty or damaged, do not use.

Cautions:

- The PRECICE Intramedullary Limb Lengthening System is for prescription use only by the order of a physician.
- Device should be removed after implantation time of no more than one year.
- Utilize extreme caution when handling instruments made from magnetic materials such as stainless steel in proximity of the magnet of the PRECICE Intramedullary Limb Lengthening nail, as materials will be attracted to each other.
- After the surgical procedure is complete, if retraction is needed during the lengthening or consolidation phase, retract the device no more than the amount lengthened the preceding day. Failure to follow this caution may result in pulling biologic material that may have adhered to the rod into the internal space of the Nail.
- Do not bend the PRECICE Intramedullary Limb Lengthening nail or otherwise modify or damage the implant. During insertion of the nail, there should be caution in not hitting/impacting the nail.
- Follow the ERC Operators Manual (OM0005, OM0009, OM0016, or OM0017) to assure proper alignment between the ERC and magnet of the PRECICE Intramedullary Limb Lengthening nail.

Detail of the PRECICE Intramedullary Limb Lengthening Nail with Locking Screws.

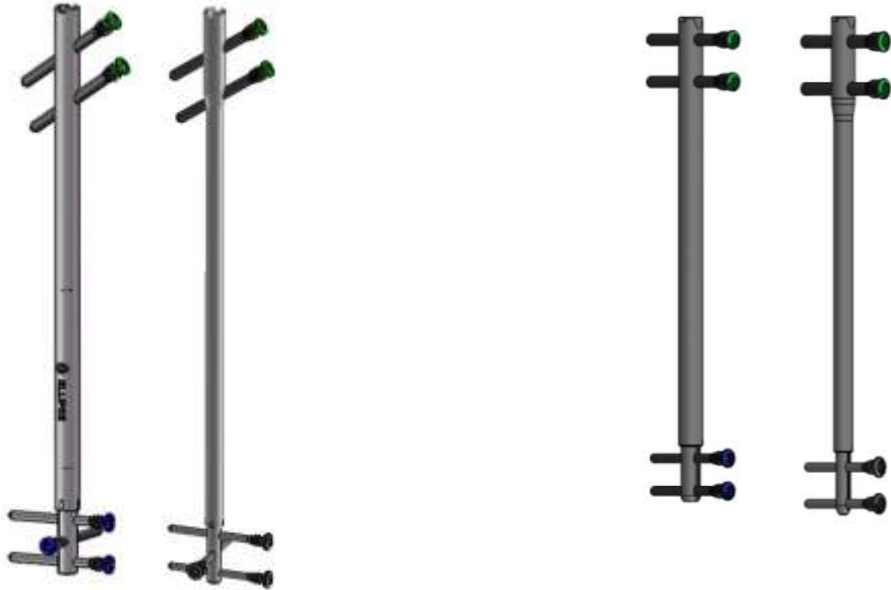

Precice IMLL Nail with Locking Screws (10.7mm on left, 8.5mm on right)

Precice-S IMLL Nail with Locking Screws (10.7mm on left, 8.5mm on right)



Precice-S IMLL Gen 2 Nail with Locking Screws (10.7mm on left, 8.5mm on right)

Drill guide set up. Verify drill bit alignment to implant prior to use.

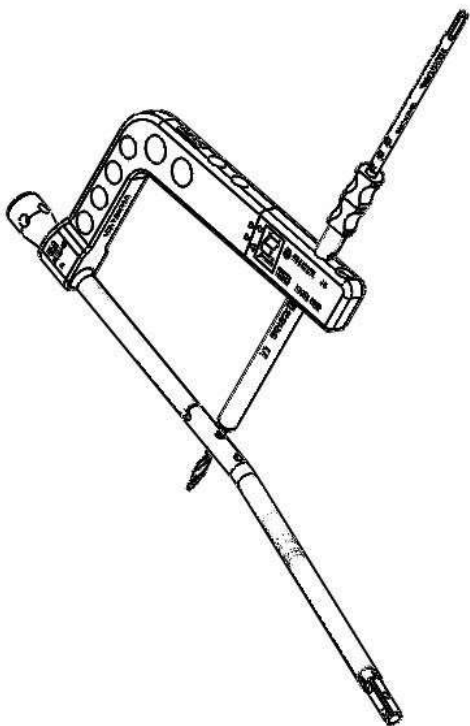

Precice IMLL Nail Model A and V – Retrograde Femur 10° Bend

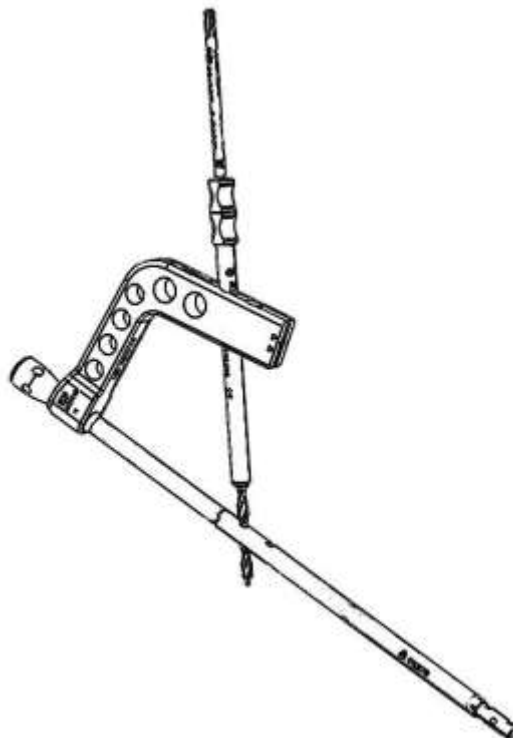

Precice IMLL Nail Model B – Antegrade Femur Piriformis

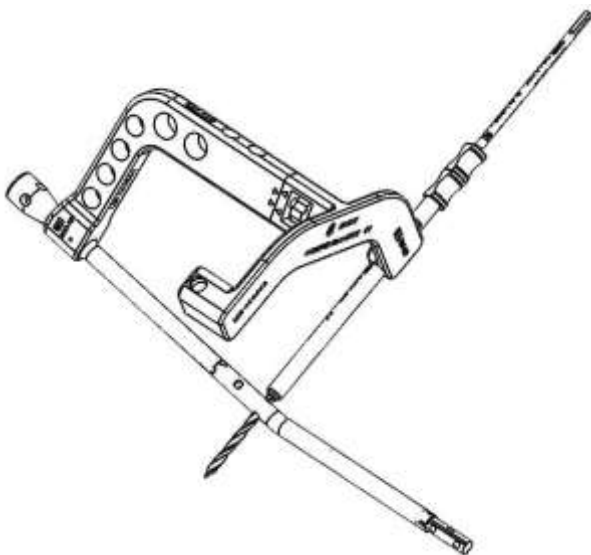

Precice IMLL Nail Model C – Antegrade Tibia 10° Bend

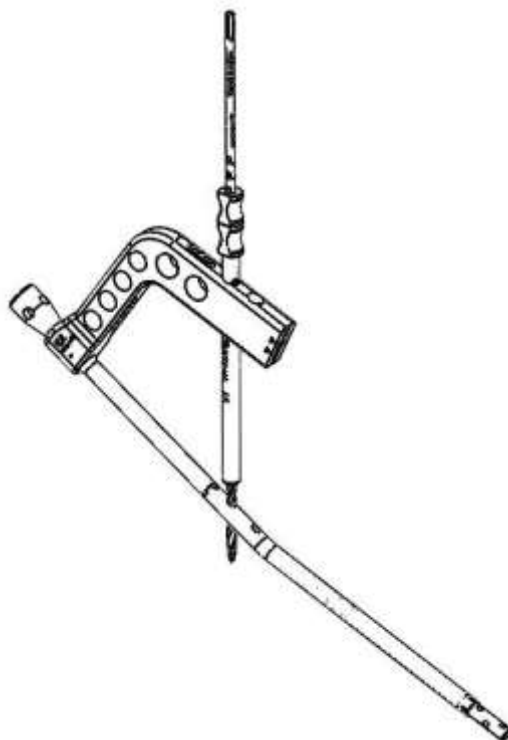

Precice IMLL Nail Model D – Antegrade Femur Trochanteric 10° Bend

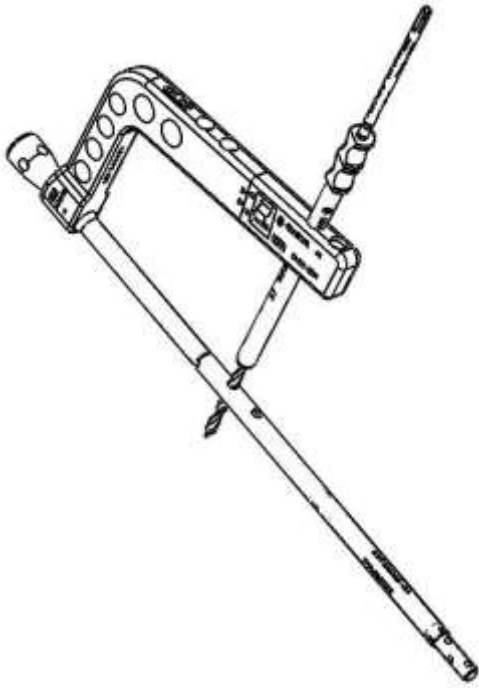

**Precice IMLL Nail Model E and X –
Retrograde Femur Straight**

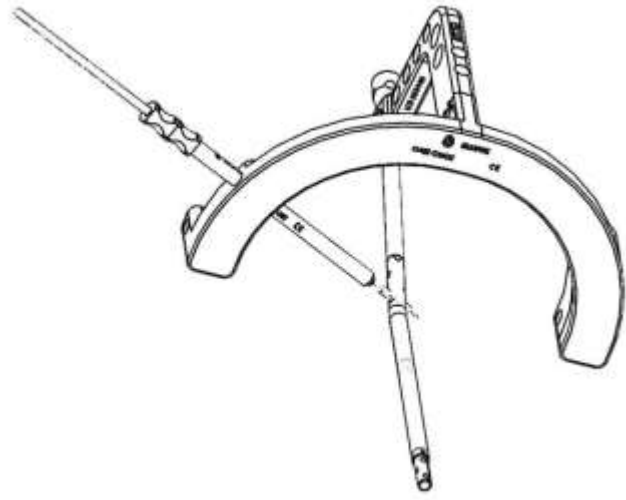

**Precice IMLL Nail Model F and G – Antegrade Tibia
10° Bend**

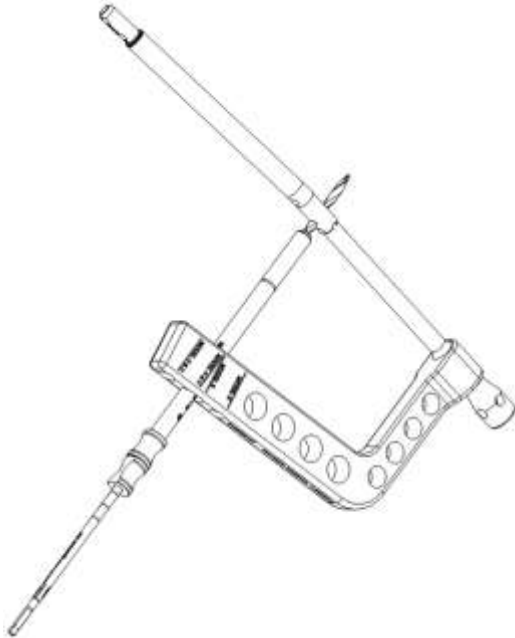

**Precice-S IMLL Nail Model H – Retrograde
Femur 10° Bend**

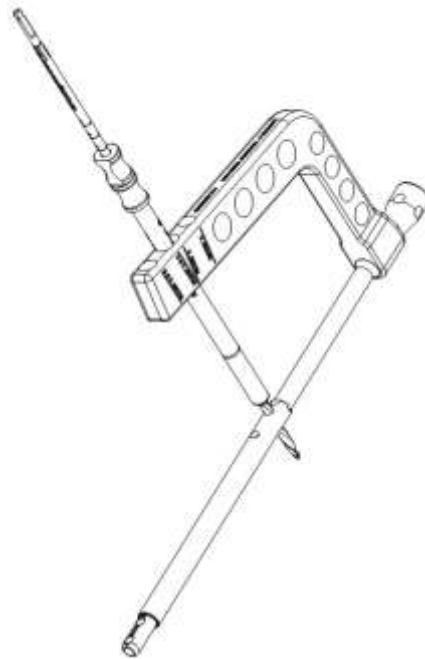

**Precice-S IMLL Nail Model U – Universal Femur
Straight**

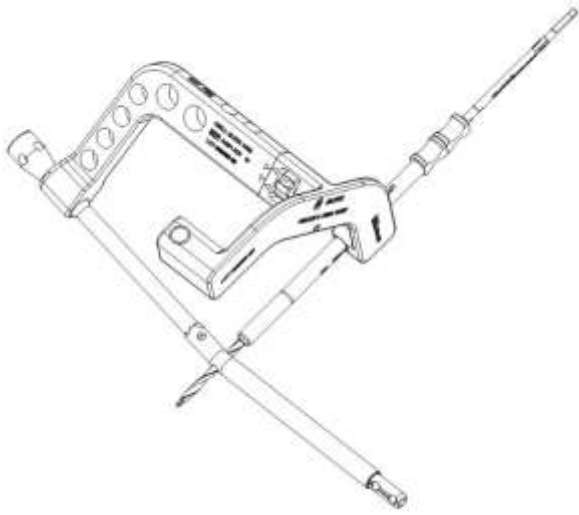

**Precice-S IMLL Nail Model J – Antegrade Tibia
10° Bend**

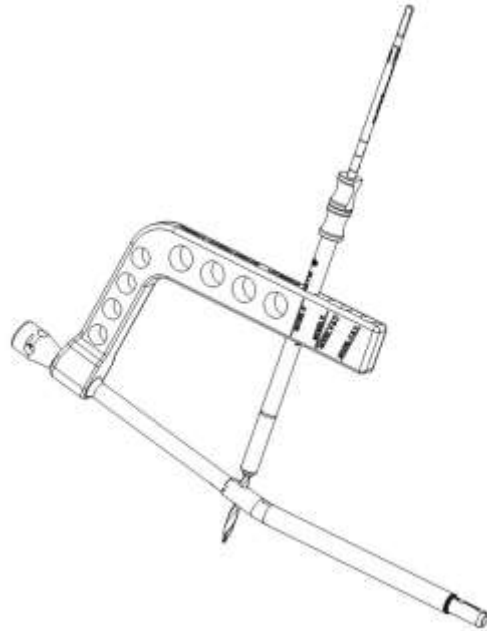

**Precice-S IMLL Nail Model K – Antegrade Femur
Trochanteric 10° Bend**

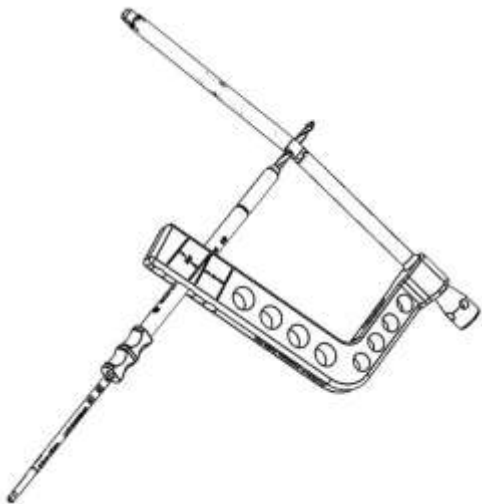

**Precice-S IMLL Nail Model P – Retrograde
Femur 10° Bend**

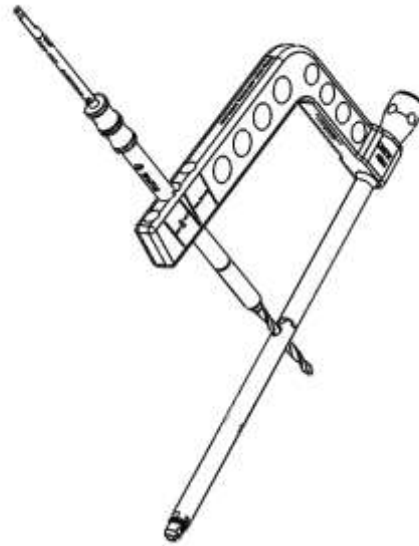

**Precice-S IMLL Nail Model N – Universal Femur
Straight**

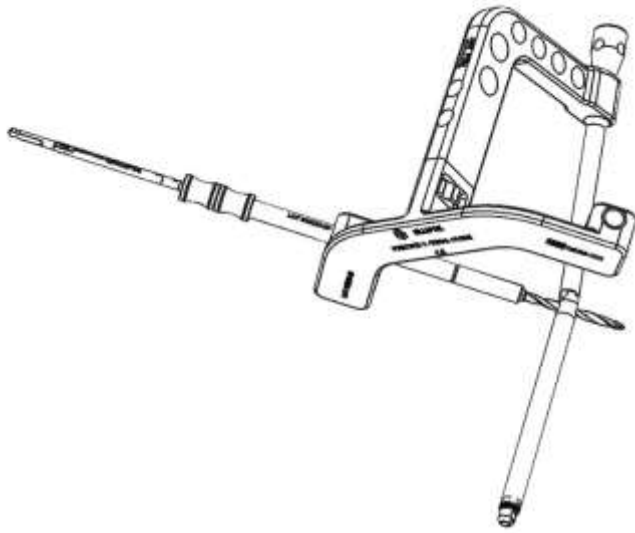

Precice-S IMLL Nail Model Q – Antegrade Tibia 10° Bend

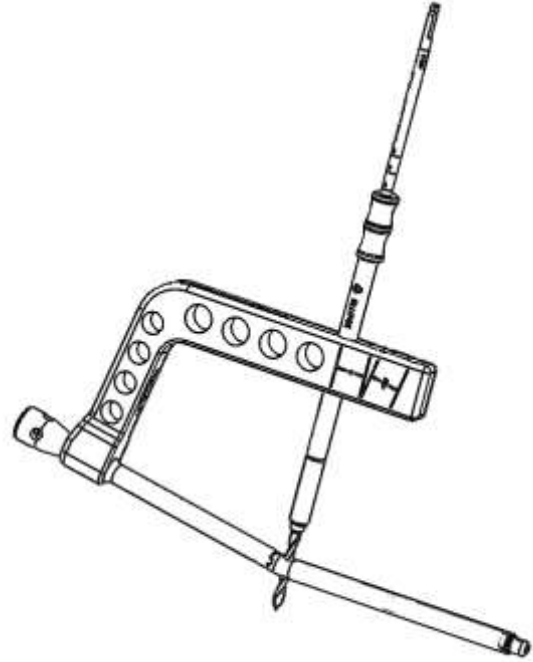

Precice-S IMLL Nail Model M – Antegrade Femur 10° Bend



Precice Humeral Nail



Removal Tool Assembly

Locking Screw Styles and Sizes

Screw Diameter	Screw Type	Head Color
3.5 mm	Peg/Bolt	Grey
4.0 mm	Peg/Bolt	Blue
	Partial Thread	Bronze
	Full Thread	Purple
5.0 mm	Peg/Bolt	Green
	Partial Thread	Aqua
	Full Thread	Gold

Locking Screw Compatibility Chart

PRECICE IMLL Models	Model Prefix	Nail Diameter	Proximal Locking Screw	Distal Locking Screw
A-G, V, X	P8.5, T8.5	8.5 mm	5.0 mm	3.5 mm
A-G, V, X	P10.7, T10.7	10.7 mm	5.0 mm	4.0 mm
A-G, V, X	P12.5, T12.5	12.5 mm	5.0 mm	5.0 mm
A-G	PR9.0, PR9.5, PR10.5	9.0 mm, 9.5 mm, 10.5 mm	5.0 mm	3.5 mm
A-G	PR11.5, PR12.5	11.5 mm and 12.5 mm	5.0 mm	4.0 mm
M, L	CDH8.5	8.5 mm	5.0 mm	3.5 mm
H, J, K, U	P8.5	8.5 mm	5.0 mm	3.5 mm
H, J, K, U	P10.7	10.7 mm	5.0 mm	4.0 mm
H, J, K, U	P12.5	12.5 mm	5.0 mm	5.0 mm
N, M, P, Q	P8.5, P10.7	8.5 mm, 10.7 mm	5.0 mm	4.0 mm

Procedures

Careful pre-operative diagnosis and planning, meticulous surgical technique, and extended postoperative care by experienced surgeons are essential to procedure success. Prior to use, the surgeon should be specifically trained in the use of the PRECICE Intramedullary Limb Lengthening System along with the associated instruments to facilitate correct selection, placement and security of the implant.

Implantation Procedure

For fracture reduction applications:

1. Thoroughly clean the instruments according to the parameters in Table 1 or 2 prior to sterilization.
2. Inspect the instruments after cleaning to check for damage prior to sterilization. Functional check should include ensuring mating instruments can be properly assembled and instruments with moving parts are operated to ensure correct operation.
3. Sterilize locking screws (if provided non-sterile) and instrument trays prior to the procedure. The PRECICE Intramedullary Limb Lengthening Nail is provided separately in sterile packaging. The Precice Screws are provided non-sterile or sterile, check labeling before proceeding.
4. Position patient per standard technique.
5. Check for length and rotation by comparison to the unaffected limb.
6. Intra-articular fracture components should be addressed with interfragmentary screw fixation prior to nail insertion. Care should be taken to place the screws in the anterior and posterior aspect of the distal long bone and safely out of the nail's intended path.
7. Identify and access the appropriate entry point for the delivery technique chosen (i.e., antegrade or retrograde).
 - The Humeral Nail is inserted through a central entry point at the apex of the humeral head, in line with the medullary canal in both AP and lateral views. This entry point can be accessed via an anterolateral approach. Care should be taken to avoid the supraspinatus tendon insertion in the rotator cuff. The rotator cuff should be protected throughout surgery.
8. Reduce the fracture using standard surgical technique.
9. Determine the appropriate nail size and configuration to be used.
 - The distal tip of the Humeral Nail should be at least 1-2 cm proximal to the olecranon fossa.
 - It is recommended to select an implant length that will provide a minimum of 2 cm of housing tube following total lengthening distal to the fracture/osteotomy site.
10. If using flexible reamers, insert a guide wire into the medullary canal and advance until the tip of the wire reaches the intended location. Imaging in two planes is required while advancing the guide wire.
11. Ream the intramedullary canal sequentially in half millimeter increments to a size 1.0 to 1.5 mm larger than the selected nail diameter.
12. After attaching the Drill Guide to the implant, insert the PRECICE Intramedullary Limb Lengthening Nail into the medullary canal under image intensification. Advance the PRECICE Intramedullary Limb Lengthening Nail until the device is properly positioned.
 - It is recommended to counter-sink the Humeral Nail 5 mm below the articular surface to avoid subacromial impingement and the incidence of shoulder pain. The distal end of the Humeral Nail should be at least 1-2 cm proximal to the olecranon fossa.
 - The proximal end of the Humeral Nail should be seated in subchondral bone, just below the articular surface of the proximal humerus. If needed, end caps of up to 15mm in length can be used for the nail.

13. Using the Drill Guide mounted to control alignment, secure the proximal portion of the lengthener using proximal locking screws of appropriate length. The head of the screw should be flush with the bone surface. Do not drill additional holes until securing the previous locking screw.
14. Using a free hand technique and fluoroscopic imaging, secure the distal portion of the lengthener using distal locking screws of appropriate length. The head of the screw should be flush with the bone surface.
15. Remove the Drill Guide and associated accessories and carefully irrigate to remove any remaining bone fragments. Attach the End Cap to the proximal end of the PRECICE Intramedullary Limb Lengthening Nail. Carefully irrigate the surgical site to remove any remaining bone fragments.
16. Disassemble the Drill Guide in reverse order from Step 12 prior to cleaning. Clean instruments after use, without allowing instruments to completely dry prior.
17. To provide compression to the reduced fracture, cover the ERC with sterile drape. Locate the ERC magnets over the actuator position and activate the ERC to shorten the implant. The implant may be shortened by up to 20 mm (depending on selected implant) to provide this amount of compression to the reduced fracture. Use radiography to ensure that the implant has retracted the desired amount.
18. Locate the center of the implanted magnet and mark with indelible marker.
19. Close and dress the site using standard techniques.
20. Instruct the patient to maintain the indelible marker mark at the same location.

For limb lengthening applications:

1. Thoroughly clean the instruments according to the parameters in Table 1 or 2 prior to sterilization.
2. Inspect the instruments after cleaning to check for damage prior to sterilization. Functional check should include ensuring mating instruments can be properly assembled and instruments with moving parts are operated to ensure correct operation.
3. Sterilize locking screws (if provided non-sterile) and instrument trays prior to the procedure. The PRECICE Intramedullary Limb Lengthening nail is provided separately in sterile packaging. The Precice Screws are provided non-sterile or sterile, check labeling before proceeding.
4. Use standard surgical techniques to provide for adequate venting of the intramedullary canal during surgery.
5. After accessing the insertion site, use an awl or sterile entry drill to open the medullary canal. Use care to keep the straight part of the shaft of the instrument parallel to the long axis of the bone shaft.
6. If using flexible reamers, insert a guide wire into the medullary canal and advance until the tip of the wire reaches the intended location. Imaging in two planes is required while advancing the guide wire.
7. Ream the intramedullary canal 2 mm greater than the diameter of the PRECICE Intramedullary Limb Lengthening nail. The cortices must be at least 3mm thick at any location once reamed.
8. Create an osteotomy at the appropriate location in the bone.
 - Note: Do not perform the osteotomy in the proximal or distal metaphyseal areas where the larger intramedullary canal diameter may lead to instability of the distracted fragment, and higher bending moments may result in excessive loading of the implant.
9. For tibial cases, also create an osteotomy in the fibula. To ensure that the fibula lengthens with the tibia, consider using screws to secure the osteotomized fibula to the tibia both distally and proximally.
10. After attaching the Drill Guide to the PRECICE Intramedullary Limb Lengthening nail and tightening down the Locking Bolt and Impactor with a tommy bar or 6mm driver, insert the device into the medullary canal under image intensification. Advance the device until it is properly positioned.

11. Use the Drill Guide to control alignment and then secure the proximal portion of PRECICE Intramedullary Limb Lengthening nail using two proximal transverse locking screws of appropriate length. The head of the screw should be flush with the bone surface. Do not drill a second hole until securing the first locking screw. Using a free hand technique and fluoroscopic imaging, secure the distal portion of the PRECICE Intramedullary Limb Lengthening nail using two transverse locking screws of appropriate length. The head of the screw should be flush with the bone surface.
12. Remove the Drill Guide and associated accessories. Attach the End Cap to the proximal end of the PRECICE Intramedullary Limb Lengthening nail. Carefully irrigate the surgical site to remove any remaining bone fragments.
13. Disassemble the Drill Guide in reverse order from Step 10 prior to cleaning. Clean instruments after use, without allowing instruments to completely dry prior.
14. Locate the center of the implanted magnet and mark the patient's skin with indelible marker at this location.
15. Close and dress the site using standard techniques.
16. Instruct the patient to maintain the indelible marker mark at the same location on their limb.

Post-Operative Procedures

1. Read the External Remote Controller (ERC) Operator's Manual (OM0005, OM0009, OM0016, or OM0017) prior to performing an adjustment of the PRECICE Intramedullary Limb Lengthening nail.
2. Determine the amount of adjustment required to compensate for any length discrepancy between the treated limb and the unaffected limb or any additional compression or distraction desired.
3. Identify the mark on the limb where the magnet in the PRECICE Intramedullary Limb Lengthening nail is located. Carefully place the ERC firmly but comfortably over this area in the correct orientation.
4. Retract or distract the implant to the desired amount, as viewed on ERC display screen. Retraction should only be performed by a physician with the aid of radiography.
5. Carefully place the ERC back in its storage container and close.
6. The progress and efficacy of lengthening should be checked regularly against follow-up radiographic evidence of the rate of lengthening and the quality of the regenerate. While 1 mm per day is generally recommended, clinical and radiographic examination may show that lengthening should progress at a faster or slower pace. Weekly X-ray imaging to assess actual distraction length, bone regenerate, and device integrity is recommended. There should be consideration for onset of pain in regular follow ups.

Implant Removal Procedures

1. At the time deemed appropriate by the physician, remove the PRECICE Intramedullary Limb Lengthening nail using standard surgical technique.
2. Follow all cleaning and sterilization procedures to prepare the instruments prior to removal.
3. Access the distal end of the PRECICE Intramedullary Limb Lengthening nail and attach the removal instrumentation.
4. Once all of the locking screws have been removed, the PRECICE Intramedullary Limb Lengthening nail can be removed by using the removal tool assembly which consists of the locking rod, removal rod and the slap hammer. Disassemble removal tool assembly prior to reprocessing after the removal surgery.
5. Close and dress the wound using standard surgical techniques.
6. Return the explanted product to NuVasive Specialized Orthopedics following instructions provided. Please call 1-866-456-2871 to obtain instructions or if you have any questions.

Cleaning and Sterilization Instructions

The Instrument Tray, Locking Screw Tray (if screws are provided non-sterile), and instruments are provided non-sterile and must be cleaned and sterilized prior to use. The Precice Screws are provided non-sterile or sterile, check labeling before proceeding. These instructions are provided in accordance with AAMI TIR12 and ISO 17664 and are intended to supplement a hospital's existing cleaning and disinfecting protocols.

Cleaning Instructions:

Thoroughly clean and inspect the trays and instruments for damage prior to loading, wrapping, and sterilization. Disassemble the Instrument Tray and Locking Screw Tray by removing the lid from the tray base. Remove the instruments from the instrument holders.

Note: Do not allow instruments to completely dry prior to cleaning.

The recommended cleaning instructions for the Instrument Tray, Locking Screw Tray, and instruments are as follows:

Table 1: Manual Cleaning Recommendations:

Step	Solution	Time (Minutes)	Temperature	Instruction
1	pH Neutral Hospital Grade Enzymatic Detergent	14-15 Minutes	Room Temperature	Disassemble instrument trays, remove the instruments from the instrument holders, and disassemble instruments before immersing, soaking, and performing the cleaning. Immerse and soak for required time.
2	pH Neutral Hospital Grade Enzymatic Detergent	As required per detergent instruction	Room Temperature	Clean thoroughly. Scrub all external surfaces with a soft bristle brush until all visible soil has been removed. It is important to make sure all areas of the tray and instruments are cleaned. Ensure that the holes and lumens are effectively cleaned by using a small diameter brush (tight-fitting, soft and non-metallic) or pipe cleaner to clean holes and lumens. Inspect for visible soil on exposed surfaces. Pay attention to threads, hinges and occluded areas of the instrument trays and instruments, and any hard-to-reach areas. Inspect for visible soil on exposed surfaces and make sure there is no visible soil on the exposed surfaces.
3	Distilled or Reverse Osmosis (RO) Water	2-3	Warm, as delivered from hot water tap	Rinse thoroughly for required time immediately after Step 2. Ensure water flows through all surfaces, perforations, holes and lumens. Inspect for visible soil on exposed surfaces and make sure there is no visible soil. Particular attention should be given to surfaces, perforations, lumens, hinges, and holes.
4	pH neutral hospital-grade enzymatic detergent	15 Minutes	40-60°C	Immerse and sonicate the instruments for the required time. The instrument trays do not require sonication.
5	Distilled or RO water	2-3	Warm, as delivered from hot water tap	Rinse thoroughly for required time immediately after Step 4. Ensure water flows through all surfaces, perforations, holes, and lumens. Visually inspect the trays and instruments for visible soil or detergent. Particular attention should be given to surfaces, perforations, lumens, hinges, and holes. Tools such as lighting, magnifying glass, or boroscope may be used to inspect lumens or holes for visible soil. Perform an additional rinse if soil or detergent is still present and visually inspect. Repeat cleaning process if soil or detergent is still present.
6	Air	As required	Ambient	Allow to air dry in clean area. Blow perforations, holes, and lumens or any internal areas with clean air using filtered air source or syringe.

Table 2: Automatic Cleaning Recommendations:

Step	Solution	Time (Minutes)	Temperature	Instruction
1	pH Neutral Hospital Grade Enzymatic Detergent	As required	Room Temperature	Disassemble instrument trays, remove the instruments from the instrument holders, and disassemble instruments before immersing, soaking, and performing the cleaning. For instruments or trays with complex design features such as perforations, lumens, holes, threads or a hard to reach area, it is necessary to soak the instruments and manually scrub all external and internal surfaces with a soft bristle brush, a small diameter brush (tight-fitting, soft and non-metallic) or pipe cleaner until all visible soil has been removed prior to automatic reprocessing to improve the removal of adherent soil.
2	pH neutral hospital-grade enzymatic detergent	15 Minutes	40-60°C	Immerse and sonicate the instruments for the required time by the manufacturer. The instrument trays do not require sonication.
3	Distilled or reverse osmosis (RO) water	2-3	Warm, as delivered from hot water tap	Rinse thoroughly for required time immediately after Step 2. Ensure water flows through all surfaces, perforations, holes and lumens.
4	N/A	N/A	N/A	Load the lid, tray base, and insert tray such that all surfaces of the trays are exposed to the cleaning solutions. Load the instruments so that cannulations, lumens or holes can drain. Do not place heavier instruments on top of delicate instruments.
5	Distilled or RO Water	6	Cold	Pre-wash
6	pH Neutral Hospital Grade Enzymatic Detergent	10	55°C	Wash
7	Distilled or RO Water	30	N/A	Rinse
8	Distilled or RO Water	5	93°C	Final Rinse
9	N/A	Vary	Room Temperature	Dry
10	N/A	N/A	N/A	Visually inspect the trays and instruments for dryness and visible soil or detergent. Particular attention should be given to surfaces, cannulas, hinges, lumens or holes. Tools such as lighting, magnifying glass, or boroscope may be used to inspect long cannulas, lumens or holes for visible soil. If soil or detergent is visible, repeat cleaning.

Sterilization Instructions:

After cleaning the instrument tray and instruments, prior to sterilization, inspect all parts of the tray and instruments for damage. A functional inspection should also be performed where possible. Mating devices should be checked for proper assembly and devices with moving parts should be operated to check for correct operation. Load the base tray with the specified instruments or locking screws and secure the tray lid. Ensure that the tray base and lid can be secured using the latches and handles. If you suspect the tray or an instrument to be damaged, do not use the tray and/or instrument and contact NuVasive Specialized Orthopedics. for a replacement and/or repair. The Instrument and Locking Screw Trays have been qualified to be sterilized in a double wrapped configuration with a legally marketed, FDA cleared sterilization wrap (Such as CSR Wrap), using the following steam sterilization cycle:

Table 3: Double Wrapped Sterilization Recommendations:

	Sterilization Temperature	Sterilization Time (Minutes)	Drying Time (Minutes)	Maximum Tray Weight
Pre-vacuum steam sterilization cycle	132° C	4	Minimum 40	25 lbs

The Instrument Tray has also been qualified to be sterilized using Aesculap Rigid Containers, US only, using the following configurations and steam sterilization cycle:

Table 4: Aesculap Container Configurations

Base Options		
Description	Aesculap NUVA PN	NuVa PN
Solid Bottom 4.75"	JK442B (screen printed)	DM-JK442B
	JK442 (laser marked)	DM-JK442B
Lid Options		
Description	Aesculap NUVA PN	NuVa PN
Aluminum Lid (Purple)	XG349	8803001
Aluminum Lid (Silver)	JK489B	8803002

Table 5: Aesculap Rigid Container Sterilization Recommendations:

	Sterilization Temperature	Sterilization Time (Minutes)	Drying Time (Minutes)	Maximum Tray Weight
Pre-vacuum steam sterilization cycle	132° C	4	Minimum 40	25 lbs

Precaution:

When sterilizing instruments and locking screws, do not load the tray more than the weight specified in Table 3 or 5 above.

Limits of Reuse:

The instrument trays are reusable and actual limits of reuse for the instrument trays are based upon the proper handling, use, care and cleaning of the trays. The end of tray life is to be determined by wear and damage due to use and through the inspection of the trays after the cleaning and sterilization cycles. Discontinue use of the device if visible signs of wear are present. This includes cracking, peeling, flaking, rusting, and/or discoloration. Always inspect the instrument trays and its components between uses. For trays and instruments that are no longer functional, or exhibit excessive wear and tear, please return them to NuVasive Specialized Orthopedics for replacement.















Storage:

Recommended storage of the Instrument Tray is at controlled ambient temperature 20°-24°C (68°-75°F). Ensure that the sterilized tray is stored in areas that provide protection from dust, moisture, insects, and extremes of temperature and humidity.

Other Information:

- Upon removal from the package, compare the descriptions on the label with the package contents (product number and size)
- Packages for each of the components should be intact upon receipt. All implants should be carefully examined for completeness, and for lack of damage, prior to use. Damaged packages or products should not be used, and should be returned to NuVasive Specialized Orthopedics.
- The PRECICE Intramedullary Limb Lengthening nail is provided sterilized by Gamma Irradiation Sterilization.
- Please refer to the package label for the expiration date of the PRECICE Intramedullary Limb Lengthening nail.
- The PRECICE Intramedullary Limb Lengthening nail is for Single Use Only.
- Do not sterilize the ERC.
- Do not attempt to re-sterilize the IMLL Device. Steam or Ethylene Oxide gas will not reach the internal components of the IMLL Device.
- Do not use if package is damaged or sterile barrier is broken.

Table 6: Symbols Definition:

Symbol	Definition
	Unsafe in Magnetic Resonance Imaging (MRI) Environments
	For Single Use Only, Do not re-use
	Do not use if package is damaged
	Do not Resterilize
	Non-Sterile, Sterilize by Steam before Use
Rx Only/ 	Federal (US) law restricts the sale of this device for use by or on the order of a physician.
	Manufacturer
	Date of Manufacture
	Model Number
	Lot Number
 www.globusmedical.com/eifu	See Instructions For Use www.globusmedical.com/eifu
	Expiration Date
	Sterilized by Gamma Irradiation
	This product has met European Union health, safety, and environmental requirements, which ensure consumer and workplace safety.

 **Manufacturer:**
 NuVasive Specialized Orthopedics
 Valley Forge Business Center
 2560 General Armistead Avenue
 Audubon, PA 19403 USA
 Customer Service:
 Phone 1-866-GLOBUS1 (OR)
 1-866-456-2871
 Fax 1-866-GLOBUS3 (OR)
 1-866-456-2873

This product, and the use thereof, may be covered by one or more of the following U.S. and/or international patents: US 7,955,357, US 7,981,025, US 8,057,472, US 8,197,490, US 8,382,756, US 8,419,734, US 8,449,543, US 8,715,159, US 8,734,488, US 8,808,163, CN 101917918, EP 2,114,258. Other U.S. and international patents pending. This product is licensed to the customer for single use only. Any reesterilization or subsequent re-use is an unlicensed use and therefore constitutes patent infringement.

 only

 0297